

D1-1502

quarter turn lock

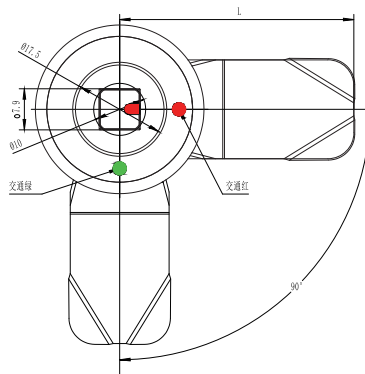
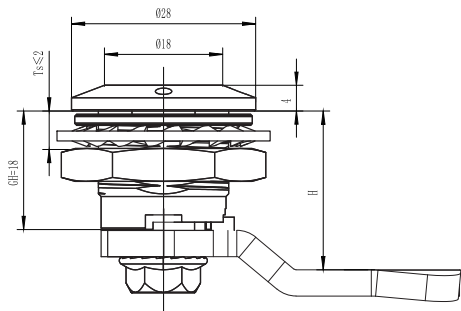

IP40

STAINLESS SERIES

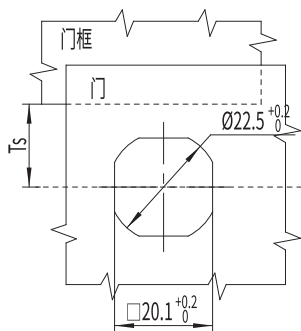

锁芯 Cylinder

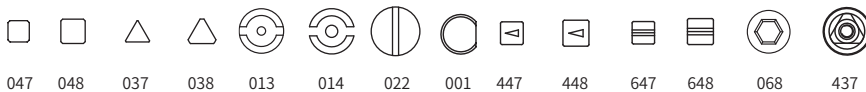

选型 Model selection

D1-1502-LH-A1

A1 代表 SUS304
A1 represents SUS304
A2 代表 SUS316
A2 represents SUS316

L 代表钢栓长度
L represents the length of the steel bolt
H 代表有效高度
H represents effective height

1. Material and surface treatment:
Main body, Steel bolt: SUS304

2. Performance parameters:
Protection class: IP40

3. Installation instructions:
Fixed screw torque 8N. M
Fixed nut torque 17N. M
Applicable door panel thickness: 1-5mm

1. 材质及表面处理:
主体, 钢栓: SUS304

2. 性能参数:
防护等级: IP40

3. 安装说明:
固定螺丝扭矩 8N.M
固定螺母扭矩 17N.M

如需获得产品 3D 模型图，请联系 WWW.FORND.COM