

quarter turn lock

D1-1444

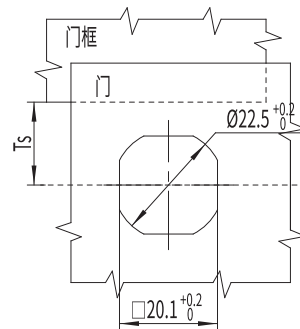

IP65

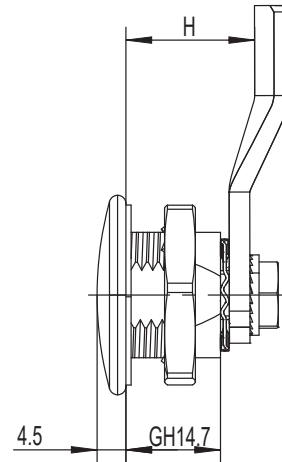
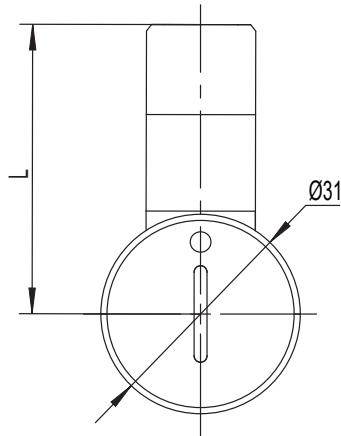

请 联 系 W W W . F O R N D . C O M 模 型 图 如 需 获 得 产 品 3 D 模 型 图

1. Material and surface treatment:
Main body : Zamak DIN-EN 1774-ZnAl4Cu1
Steel bolt: iron galvanized

2. Performance parameters:
Protection class: IP65

3. Installation instructions:
Fixed nut:
Maximum tightening torque: 10N·m

1. 材质及表面处理:
主体: 5#锌合金
钢栓: 铁镀锌
密封圈: EPDM发泡胶

2. 性能参数:
防护等级: IP65

3. 安装说明:
固定螺母:
最大拧紧力矩: 10N·m

锁芯 Cylinder

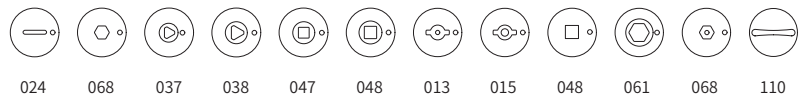

选型 Model selection

锁芯选型
Lock cylinder selection

D1-1444-SX-LH-30

30 代表电镀亮铬
30 represents electroplating bright chrome
40 代表喷塑亚光黑
40 represents Black powder coated

L 代表钢栓长度
L represents the length of the steel bolt
H 代表有效高度
H represents effective height