

B-1202

T handle lock

IP65

RL

S
SERIES

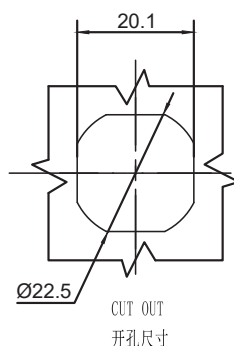
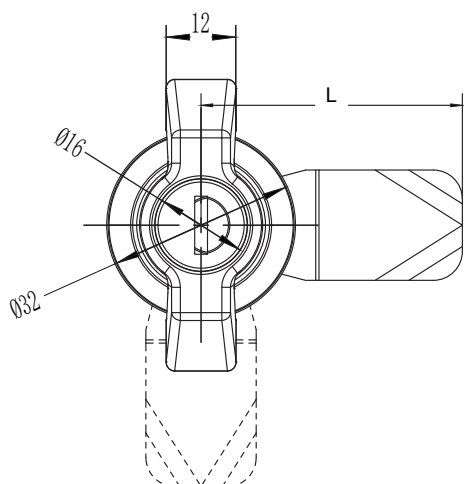
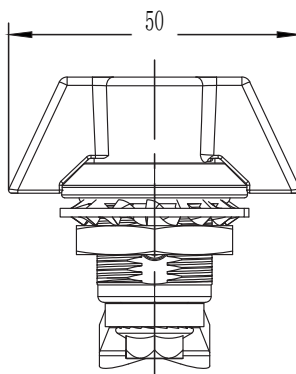
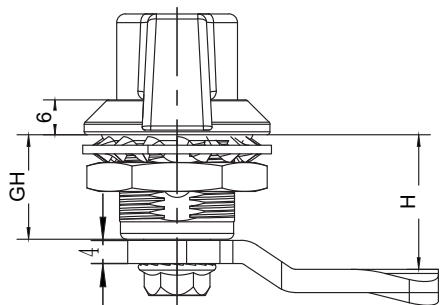

选型 Model selection

0 代表无锁芯
0 Non-locking
1 代表有锁芯
1 key locking

18 代表锁体 GH 锁体高度, 18/30/40/50/60
18 represents the height of the lock body GH
18/30/40/50/60

A1 SUS304
30 电镀铬
30 Electrochrome plating
40 粉末涂层黑
40 Powder coated black

B-1202-118-LH-A1

L 代表钢柱长度
L represents the length of the steel bolt
H 代表有效高度
H represents effective height

1. Material and surface treatment:
Main body : Zamak DIN-EN 1774-ZnAl4Cu1
or SUS304
Steel bolt: iron galvanized or SUS304

2. Performance parameters:
Protection class: IP65

3. Installation instructions:
Fixed screw torque 8N. M
Fixed nut torque 17N. M
Applicable door panel thickness: 1-8mm

1. 材质及表面处理:
主体: 5#锌合金 或 SUS304
钢栓: 铁镀锌 或 SUS304
密封圈: EPDM发泡胶

2. 性能参数:
防护等级: IP65

3. 安装说明:
固定螺丝扭矩 8N.M
固定螺母扭矩 17N.M
适用门板厚度: 1-5mm

4. 备注:
专用钥匙可选
默认 K333钥匙

如需获得产品 3D 模型图, 请联系 WWW.FORND.COM