

**C8-1561**

compression cam latch

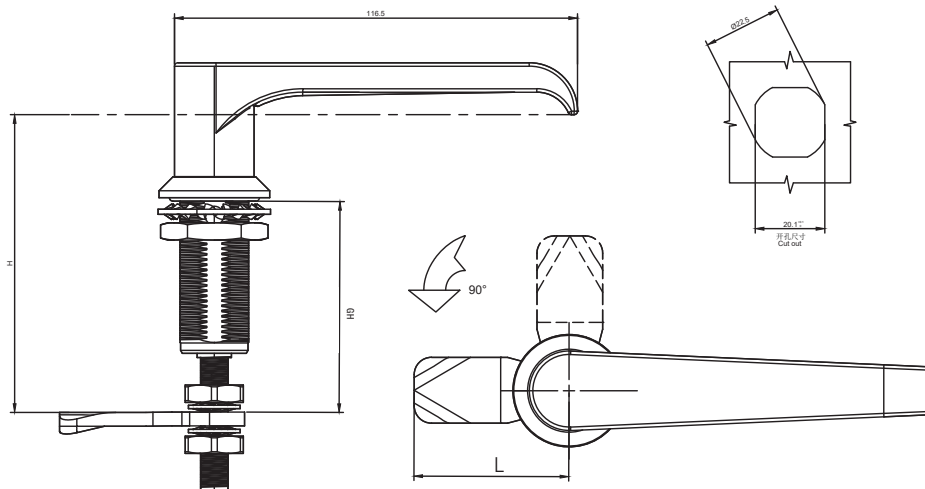

**选型 Model selection**

- 1 带锁芯
- 1 Key locking
- 0 无锁芯
- 0 Non - Locking

- 30 代表电镀亮铬
- 30 represents electroplating bright chrome
- 40 代表喷塑亚光黑
- 40 represents Black powder coated
- A1 代表 SUS304
- A1 represents SUS304

**C8-1560-100-LH-A1L**

- L 代表钢栓长度
- L represents the length of the steel bolt
- H 代表有效高度
- H represents effective height

**旋转 Rotate**

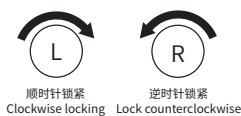

1. Material and surface treatment:  
Main body, Steel bolt: SUS304 or SUS316  
Sealing ring: EPDM foam.

2. Performance parameters:  
Protection class: IP65  
Unlocking torque:  $\leq 0.79\text{N}\cdot\text{M}$   
Ultimate load: 700N  
Tensioning and stretching amount: 7mm

3. Installation instructions:  
Fixed screw torque 10N. M  
Fixed nut torque 17N. M  
Applicable door panel thickness: 1-15mm

1. 材质及表面处理:  
主体, 钢栓: SUS304 或 SUS316  
密封圈: EPDM发泡胶。

2. 性能参数:  
防护等级: IP65  
解锁扭矩: 小于等于 0.79N·M  
极限载荷: 700N  
拉紧伸缩量: 7mm

3. 安装说明:  
固定螺丝扭矩 10N.M  
固定螺母扭矩 17N.M  
适用门板厚度: 1-15mm

如需获得产品 3D 模型图，请联系 WWW.FORND.COM