

quarter turn lock

D1-1422



IP65

RL

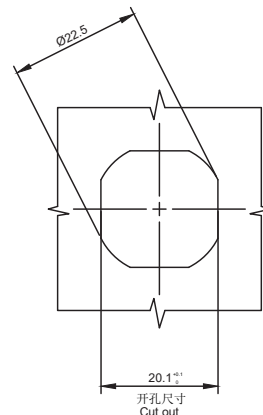
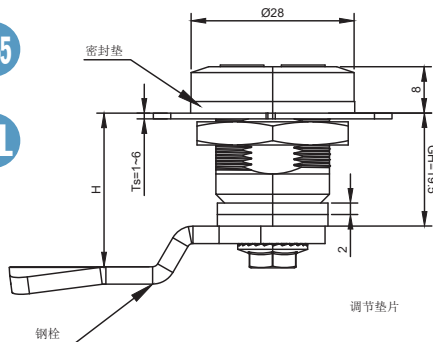

K-151

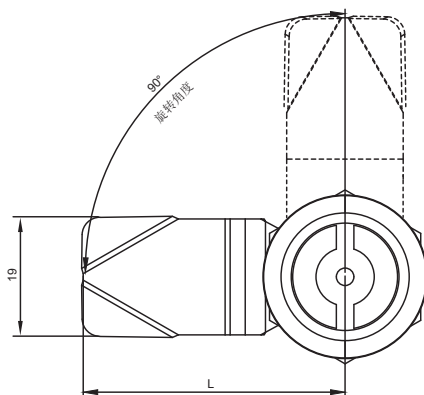

选配
Matching

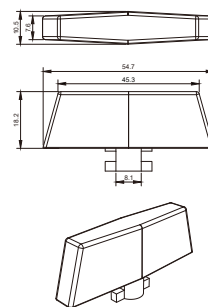

锁芯 Cylinder



047



037



013



014

选型 Model selection

锁芯选型
Lock cylinder selection

D1-1422-SX-LH-40

30 代表电镀亮铬
30 represents electroplating bright chrome
40 代表喷塑亚光黑
40 represents Black powder coated

L 代表钢栓长度
L represents the length of the steel bolt
H 代表有效高度
H represents effective height

如需获得产品3D模型图，请联系 WWW.FORND.COM

1. Material and surface treatment:
Main body : Zamak DIN-EN 1774-ZnAl4Cu1

Steel bolt: iron galvanized
2. Performance parameters:
Protection class: IP65

3. Installation instructions:
Fixed screw torque 8N. M
Fixed nut torque 17N. M
Applicable door panel thickness: 1-5mm

1. 材质及表面处理:
主体: 5#锌合金
钢栓: 铁镀锌
密封圈: 三元乙丙橡胶
2. 性能参数:
防护等级: IP65

3. 安装说明:
固定螺丝扭矩 8N.M
固定螺母扭矩 17N.M
适用门板厚度: 1-5mm