

Rod Control Swinghandle

A-1214



RL



IP54

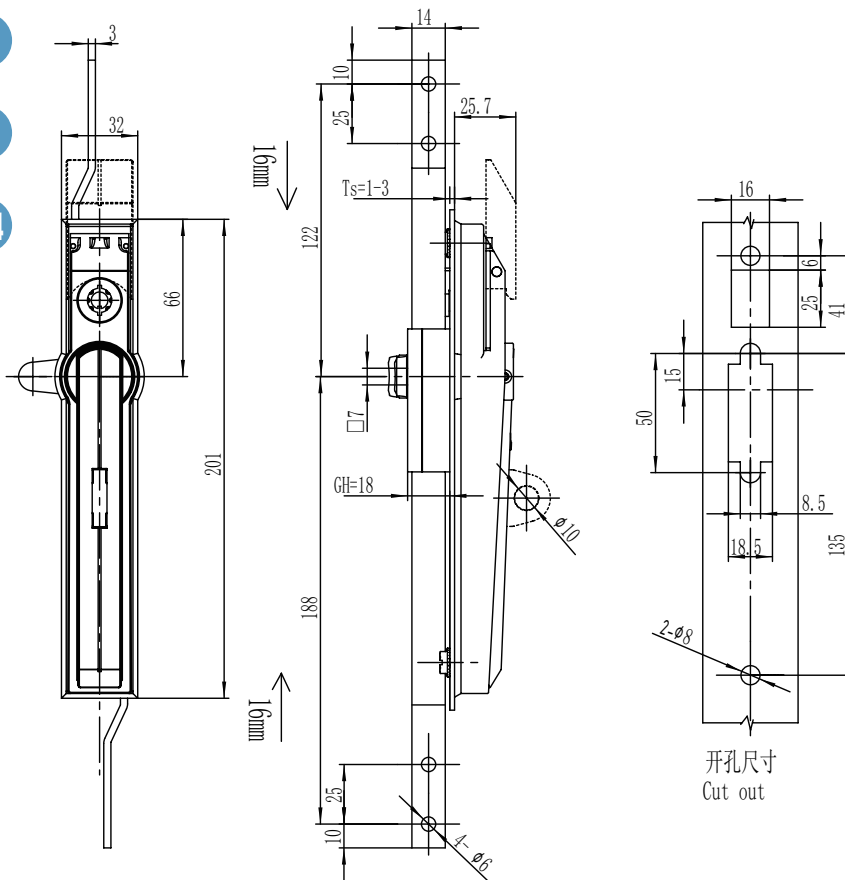

如需获得产品3D模型图，请联系 WWW.FORND.COM

1. Material and surface treatment:
Lock body, handle, dust cover : Zamak
DIN-EN 1774-ZnAl4Cu1
Steel bolt: iron galvanized
Sealing ring: EPDM foam.

2. Performance parameters:
Protection class: IP54
Handle bearing tension value: $\leq 225\text{N}$
Handle bearing torque value: $\leq 14\text{N}\cdot\text{m}$

3. Remark:
Padlockable on request

1. 材质及表面处理:
锁体, 手柄, 防尘盖: 5# 锌合金喷塑黑
螺栓: 铁镀锌
密封圈: EPDM 发泡胶。

2. 性能参数:
防护等级: IP54
手柄承载拉力值: $\leq 225\text{N}$
手柄承载扭矩值: $\leq 14\text{N}\cdot\text{m}$

3. 备注:
可配挂锁

Version C(三点拉杆型 3Prod control)		
	喷塑亚光黑 Black Powder Coated	纳米喷漆 (银亚光) NM spray painting(matte silver)
带挂 Padlockable	A-1214-3001-40	A-1214-3001-50
不带挂 Without padlock	A-1214-3012-40	A-1214-3012-50