

撞击锁 Push to close latch

B-1502

Marine latch

IP40

STAINLESS SERIES

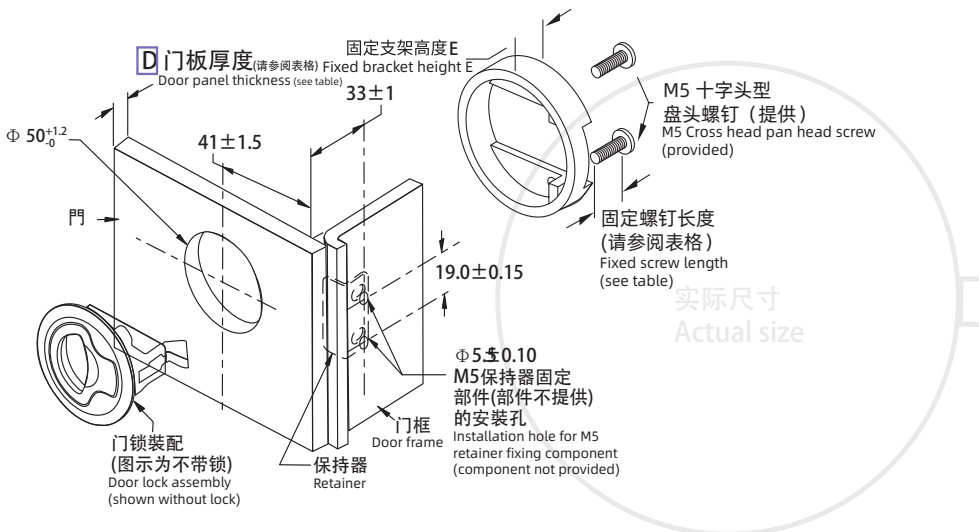
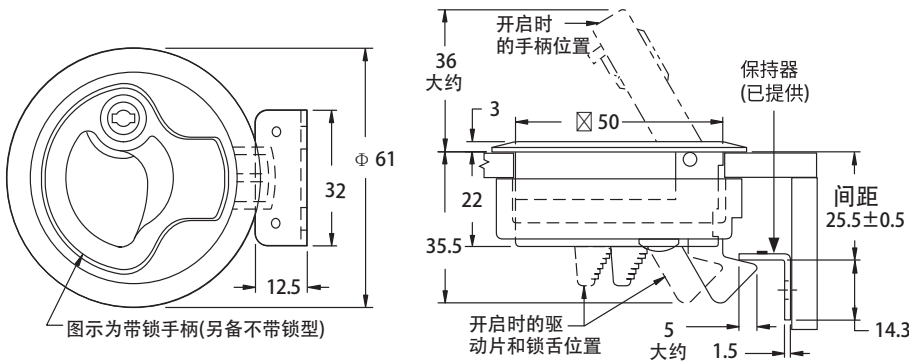

门板厚度 Panel thickness		固定支架高度 Mounting braketheight	固定螺丝高度 Fixingscrew length
最小 MIN	最大 MAX		
2	7	14	16
7	12	14	20
12	17	3.8	16
17	22	3.8	20

带锁芯型 (K170) Key Locking version (K170)			不带锁芯型 Non-locking version		
SUS304	塑料黑色 Acetal black	锌合金 Zinc alloy 亮铬 Bright Chrom	SUS304	塑料黑色 Acetal black	锌合金 Zinc alloy 亮铬 Bright Chrom
B-1502-10-A1	B-1502-10-60	B-1502-10-2-30	B-1502-20-A1	B-1502-20-60	B-1502-20-30

1. Material and surface treatment:
Lock body, handle : Zamak DIN-EN
1774-ZnAl4Cu1 or SUS304 or
PC/ABT mixture

2. Performance parameters:
Protection class: IP40
Maximum working load of stainless steel:
835N
Maximum working load of PC/ABT mixture:
270N
Working temperature range: -18 °C to 60 °C
Flame retardant grade: UL94-HB (plastic
version)

3. Remarks:
Default Keyed K170

1. 材质及表面处理:
锁体, 手柄: 5# 锌合金喷塑黑或 SUS304 或
PC/ABT 混合物

2. 性能参数: 防护等级: IP40
不锈钢最大工作载荷: 835N
PC/ABT 混合物最大工作载荷: 270N
工作温度范围: -18°C到 60°C
阻燃等级: UL94-HB(塑料版)

3. 备注:
默认 K170 钥匙

如需获得产品 3D 模型图, 请联系 WWW.FORND.COM