

A-1547

Compression latch

IP65

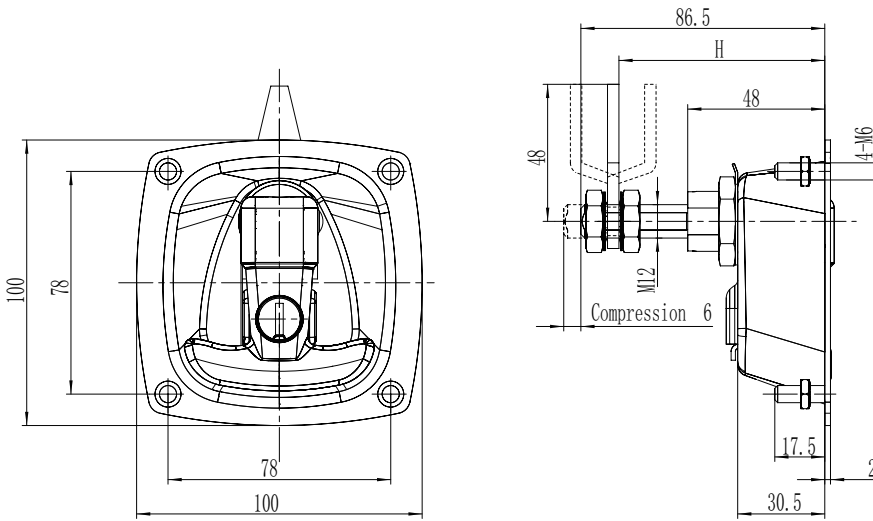

开孔尺寸
Cut out



1. Material and surface treatment:
Lock body, handle: Zamak DIN-EN 1774-ZnAl4Cu1 or SUS304
Steel bolt: iron galvanized
Sealing ring: EPDM foam.

2. Performance parameters:
Protection class: IP65
Compression force: 6.4mm
Maximum static load: 1000N

3. Remark:
Default CH751 key code

1. 材质及表面处理:
锁体, 手柄: 5#锌合金 或 SUS304
螺栓: 铁镀锌
密封圈: EPDM发泡胶。

2. 性能参数:
防护等级: IP65
压紧力: 6.4mm
最大静载荷: 1000N

3. 备注:
默认 CH751 钥匙

间距 Grip Range	锌合金 Zinc alloy		SUS304			
	最小 MIN	最大 MAX	不带钥匙锁 Non-locking	CH751 钥匙锁定 CH751 keylocking	不带钥匙锁 Non-locking	CH751 钥匙锁定 CH751 keylocking
28	43	A-1547-1010-40	A-1547-2010-40	A-1547-1010-A1	A-1547-2010-A1	A-1547-1010-A1
43	58	A-1547-1020-40	A-1547-2020-40	A-1547-1020-A1	A-1547-2020-A1	A-1547-1020-A1
58	73	A-1547-1047-40	A-1547-2047-40	A-1547-1047-A1	A-1547-2047-A1	A-1547-1047-A1
73	88	A-1547-1040-40	A-1547-2040-40	A-1547-1040-A1	A-1547-2040-A1	A-1547-1040-A1
88	104	A-1547-1050-40	A-1547-2050-40	A-1547-1050-A1	A-1547-2050-A1	A-1547-1050-A1