

T handle lock

B-1201



IP65

RL

S
SUS304 SERIES

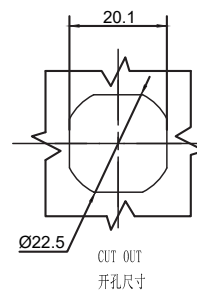
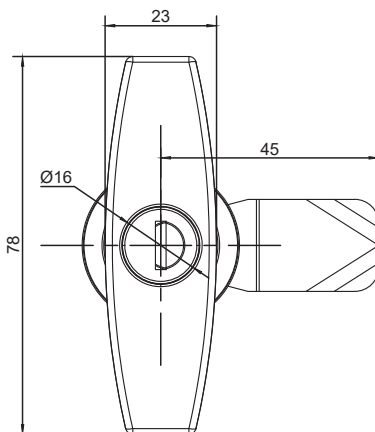
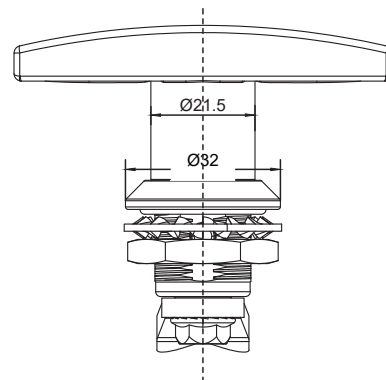
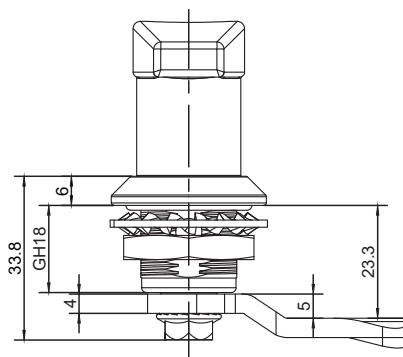

如 需 获 得 产 品 3 D 模 型 图 ， 请 联 系 W W W . F O R N D . C O M

1. Material and surface treatment:
Lock body, handler : Zamak DIN-EN 1774-ZnAl4Cu1 or SUS304
Steel bolt: iron galvanized
Sealing ring: EPDM foam.

2. Performance parameters:
Protection class: IP65

3. Remarks:
Optional dedicated key
Default K333 key

1. 材质及表面处理:
锁体, 手柄: 5#锌合金喷塑黑或 SUS304
钢栓: 铁镀锌
密封圈: EPDM发泡胶

2. 性能参数: 防护等级: IP65

3. 备注:
专用钥匙可选
默认 K333 钥匙

选型 Model selection

0 代表无锁芯
0 Non-locking
1 代表有锁芯
1 key locking

18 代表锁体 GH 锁体高度, 18/30/40/50/60
18 represents the height of the lock body GH
18/30/40/50/60

A1 SUS304
30 电镀铬
30 Electrochrome plating
40 粉末涂层黑
40 Powder coated black

B-1201-118-LH-A1

L 代表钢栓长度
L represents the length of the steel bolt
H 代表有效高度
H represents effective height