

Compression latch

A-1545

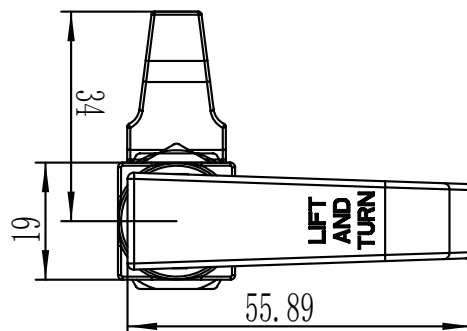
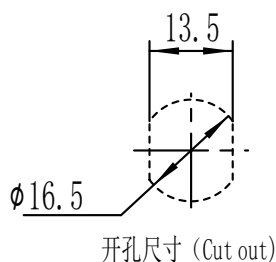
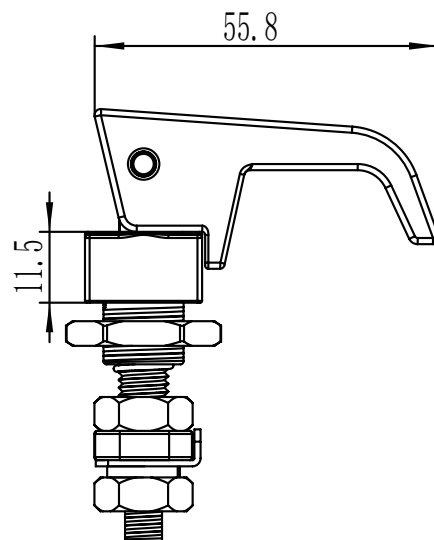
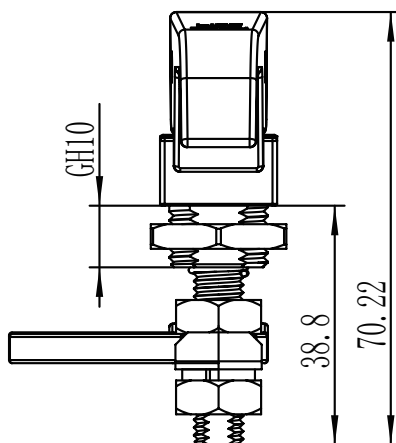

如需获得产品3D模型图，请联系 WWW.FORND.COM

1. Material and surface treatment:
Lock body, handle: Zamak DIN-EN 1774-ZnAl4Cu1 or SUS304
Steel bolt: iron galvanized
Sealing ring: EPDM foam.

2. Performance parameters:
Protection class: IP54
Compression force: 5mm
Maximum static load: 550N

1. 材质及表面处理:
锁体, 手柄: 5#锌合金或 SUS304
螺栓: 铁镀锌
密封圈: EPDM发泡胶。

2. 性能参数:
防护等级: IP54
压紧力: 5mm
最大静载荷: 550N

止口高度 Grip-Range		锌合金 Zinc alloy	SUS304	
正 Pawl Forward	反 Pawl Reversed	喷塑亚光黑 Black powder coated	亮铬 Bright Chrome	拉丝抛光 Polishing
MIN~MAX	MIN~MAX			
	42~52	A-1544-11-40	A-1544-11-30	A-1544-11-A1
2~12	32~42	A-1544-12-40	A-1544-12-30	A-1544-12-A1
12~22	22~32	A-1544-13-40	A-1544-13-30	A-1544-13-A1