

## B-1110

## T handle lock

IP40

RL

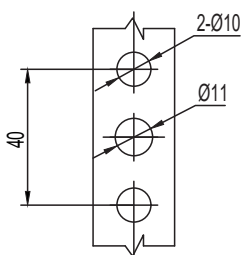
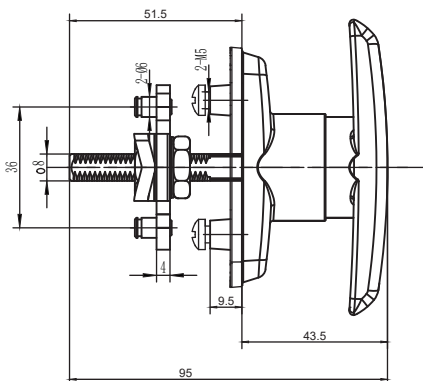
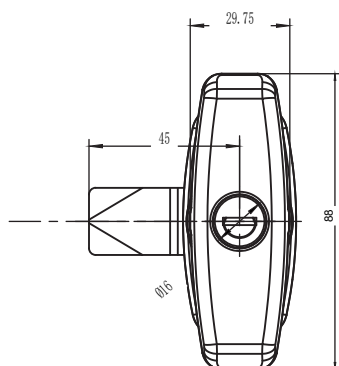

开孔尺寸Cut out

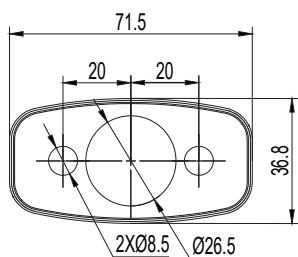
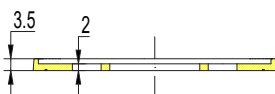

选配 epdm 防水垫

Optional epdm waterproof mat

1. Material and surface treatment:  
Lock body, handle: PA66+30%GF  
Steel bolt: iron galvanized

2. Performance parameters:  
Protection class: IP40

3. Remarks:  
Optional dedicated key  
Default K160 key  
Optional EPDM rubber pad

1. 材质及表面处理:  
锁体, 手柄: PA66+30%GF  
钢栓: 铁镀锌

2. 性能参数: 防护等级: IP40

3. 备注:  
专用钥匙可选  
默认 K160 钥匙  
EPDM的橡胶垫可选

尼龙, 黑色 PA66+30GF Black	
左向 lift	B-1110-L-60
右向 right	B-1110-R-60