

Rod Control Swinghandle

A-1218



RL



IP65

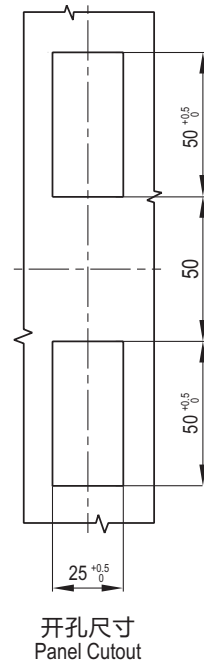
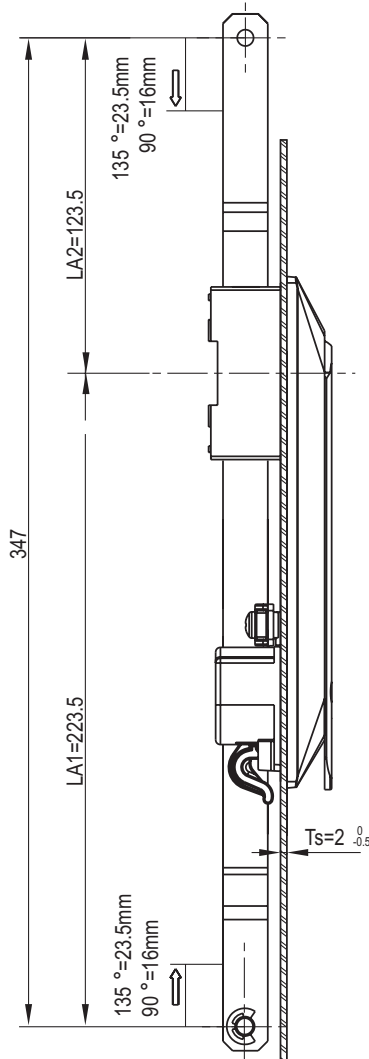
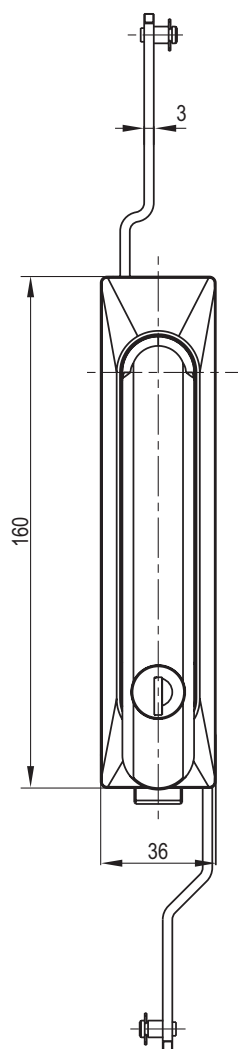

如需获得产品3D模型图，请联系 WWW.FORND.COM

1. Material and surface treatment:
Lock body, handle: PA66+30%GF;
Zamak DIN-EN 1774-ZnAl40Cu1
Steel bolt: iron galvanized
Sealing ring: EPDM foam.

2. Performance parameters:
Protection class: IP65
Handle bearing tension value: $\leq 390\text{N}$
Handle bearing torque value: $\leq 12\text{N}\cdot\text{m}$
Maximum static load: 300N

3. Remark:
Key different on request
CH751 key code on request
Padlockable on request
Default keyed K333

1. 材质及表面处理:
锁体, 手柄: PA66+30%GF
钢栓: 铁镀锌
密封圈: EPDM发泡胶。

2. 性能参数:
防护等级: IP65
手柄承载拉力值: $\leq 390\text{N}$
手柄承载扭矩值: $\leq 12\text{N}\cdot\text{m}$
最大静载荷: 300N

3. 备注:
专用钥匙可选
CH751 钥匙可选,
可配挂锁
默认K333钥匙

Version B (2点拉杆型 2Prod cotrol)	Version C (三点拉杆型 3Prod control)
A-1218-2001-60	A-1218-3001-60