

A-1217 Rod Control Swinghandle

RL

3

IP65

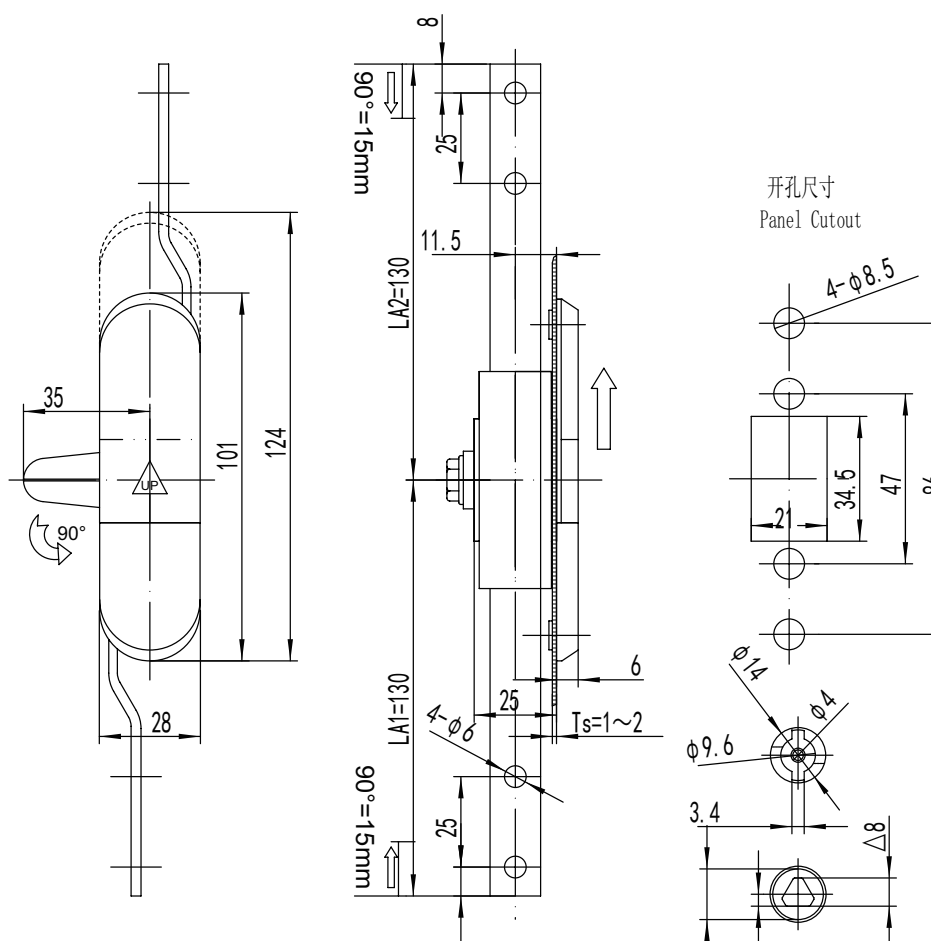

1. Material and surface treatment:
Lock body, handle: Zamak DIN-EN 1774-ZnAl4Cu1
Steel bolt: iron galvanized
Sealing ring: EPDM foam.

2. Performance parameters:
Protection class: IP65
Input torque value: $\leq 9\text{N}\cdot\text{m}$

1. 材质及表面处理:
锁体, 手柄: 5#锌合金喷塑
螺栓: 铁镀锌
密封圈: EPDM发泡胶

2. 性能参数:
防护等级: IP65
输入扭矩值: $\leq 9\text{N}\cdot\text{m}$

Version C(三点拉杆型 3Prod control)	
纳米喷漆 (银亚光)NM spray painting(matte silver)	
双翅锁芯 Double Bit	三角锁芯 Triangular
A-1217-3001-50	A-1217-3003-50

如需获得产品 3D 模型图 , 请联系 WWW.FORND.COM