

RV door latch

B-1612

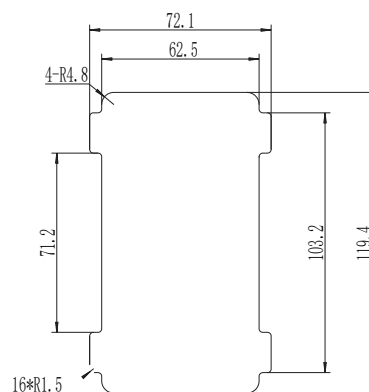

IP65

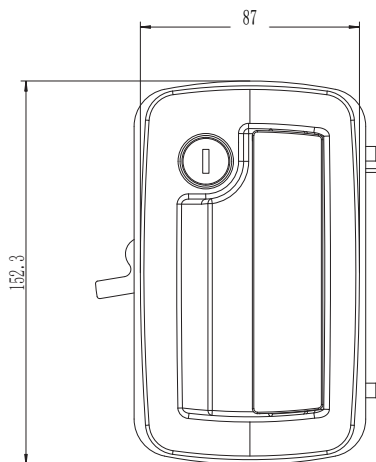
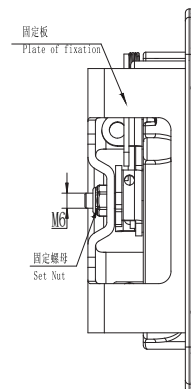
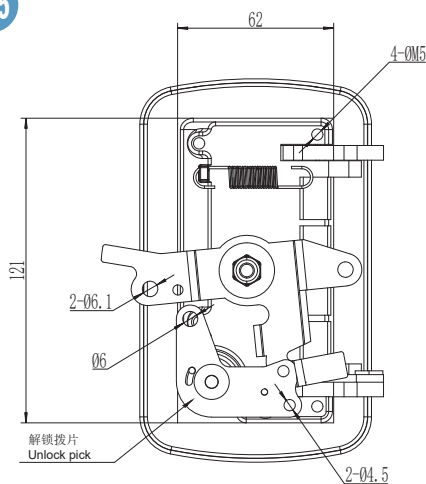

开孔尺寸
Panel Cutout

如需获得产品3D模型图，请联系 WWW.FORND.COM

1. Material and surface treatment:
Lock body, handle : Zamak DIN-EN 1774-ZnAl4Cu1
Sealing ring: EPDM foam.

2. Performance parameters: Protection class: IP65
3. Remarks:
Optional dedicated key
Default CH751 key

1. 材质及表面处理:
锁体, 手柄: 5# 锌合金
密封圈: EPDM 发泡胶。

2. 性能参数: 防护等级: IP65
3. 备注:
专用钥匙可选
默认 CH751 钥匙