

compression cam latch

C6-1540



RL

IP65

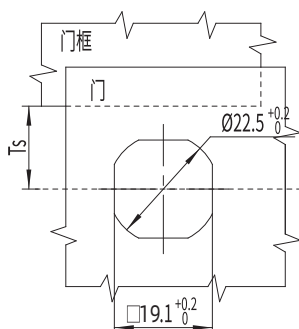
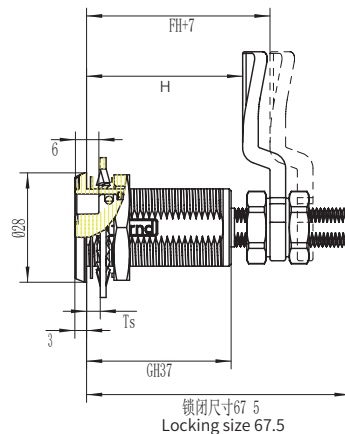
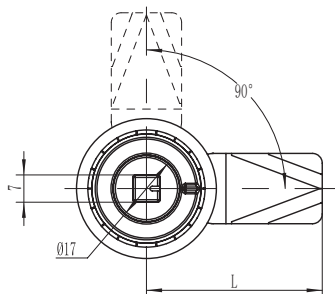

锁芯 Cylinder



选型 Model selection

锁芯选型
Lock cylinder selection

C6-1540-SX-LH-30L

30 代表电镀亮铬
30 represents electroplating bright chrome
40 代表喷塑亚光黑
40 represents Black powder coated

L 代表钢栓长度
L represents the length of the steel bolt
H 代表有效高度
H represents effective height

旋转 Rotate

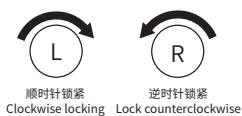

如需获得产品 3D 模型图，请联系 WWW.FORND.COM

1. Material and surface treatment:
Main body : Zamak DIN-EN 1774-ZnAl4Cu
Steel bolt: iron galvanized

2. Performance parameters:
Protection class: IP65
Unlocking torque: $\leq 0.79\text{N/M}$
Ultimate load: 700N
Tensioning and stretching amount: 7mm

3. Installation instructions:
Fixed screw torque 10N. M
Fixed nut torque 17N. M
Applicable door panel thickness: 1-5mm

1. 材质及表面处理:
主体: 5#锌合金
钢栓: 铁镀锌
密封圈: EPDM发泡胶

2. 性能参数:
防护等级: IP65
解锁扭矩: 小于等于 0.79N/M
极限载荷: 400N
拉紧伸缩量: 7mm

3. 安装说明:
固定螺丝扭矩 10N.M