

B-1606

RV door latch

IP40

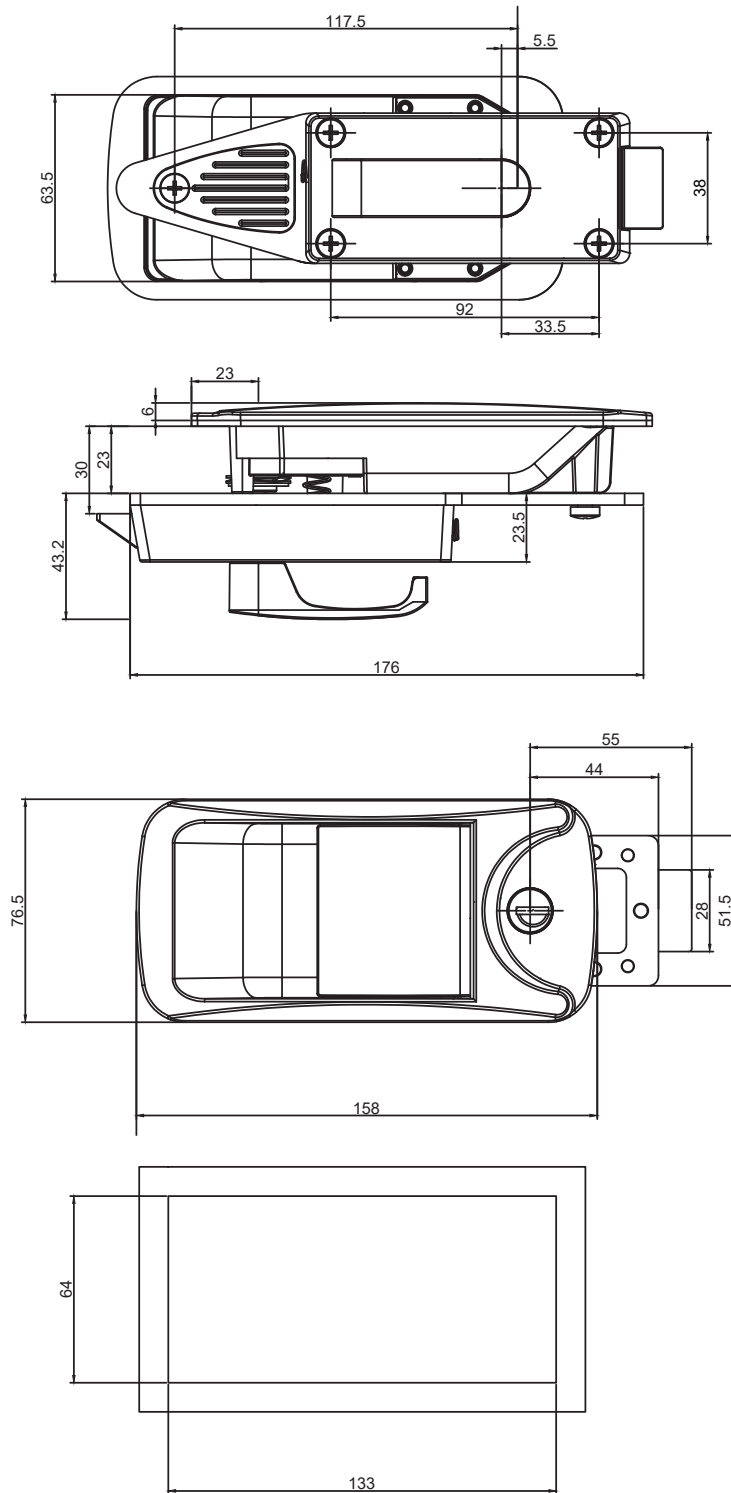

1. Material and surface treatment:
Lock body, handle : Zamak DIN-EN
1774-ZnAl4Cu1
Sealing ring: EPDM foam.

2. Performance parameters: Protection
class: IP40

3. Remarks:
Optional dedicated key
Default CH751 key

1.材质及表面处理:
锁体, 手柄: 5#锌合金
密封圈: EPDM发泡胶。

2.性能参数: 防护等级: IP40

3.备注:
专用钥匙可选
默认 CH751 钥匙

如需获得产品 3D 模型图, 请联系 WWW.FORND.COM