

Swing handle lock

A-1212

RL

IP65

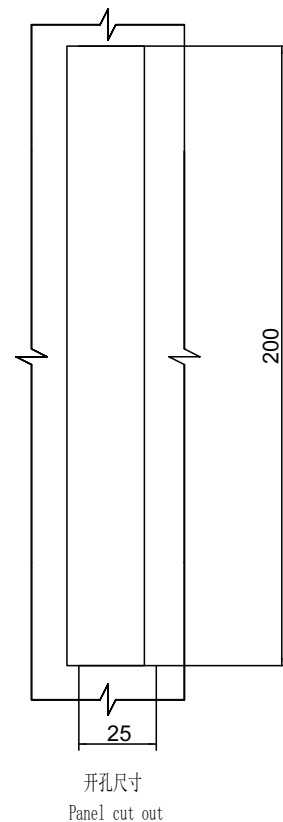
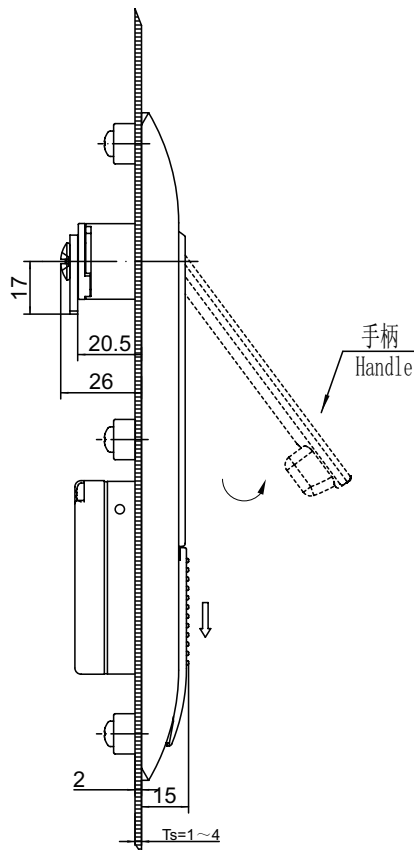
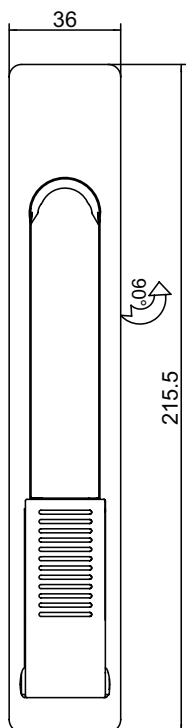
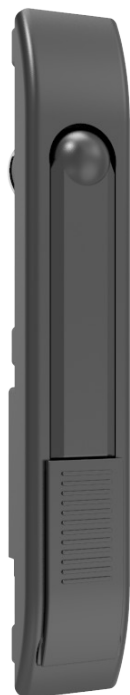

如需获得产品3D模型图，请联系 WWW.FORND.COM

1. Material and surface treatment:
Lock body: PA66+30%GF;
handle: Zamak DIN-EN 1774-ZnAl40Cu1
Steel bolt: iron galvanized
Sealing ring: EPDM foam.

2. Performance parameters:
Protection class: IP65
Handle bearing tension value: $\leq 490\text{N}$
Handle bearing torque value: $\leq 26\text{N}\cdot\text{m}$

3. Remark:
Key different on request
CH751 key code on request

1. 材质及表面处理:
锁体: PA66+30%GF
手柄: 5# 锌合金喷塑黑
钢栓: 铁镀锌
密封圈: EPDM发泡胶。

2. 性能参数:
防护等级: IP65
手柄承载拉力值: $\leq 490\text{N}$
手柄承载扭矩值: $\leq 26\text{N}\cdot\text{m}$

3. 备注: Remark
专用钥匙可选:
CH751 钥匙可选

Version A(锁舌型 Cam control)	Version C(三点拉杆型 3Prod control)
麻面黑 Black textured powder coated	麻面黑 Black Textured powder coated
A-1212-1001-60	A-1212-3001-60