

C8-1575

compression cam latch

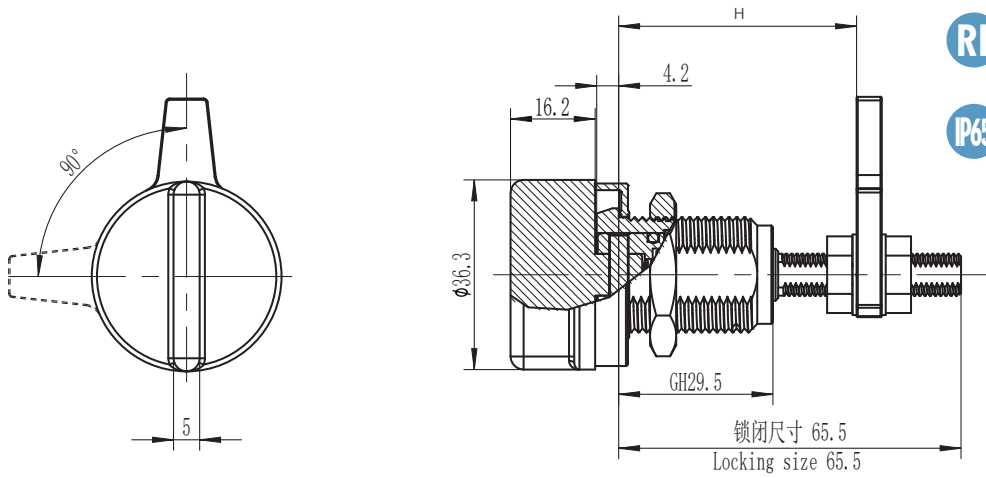

RL

IP65

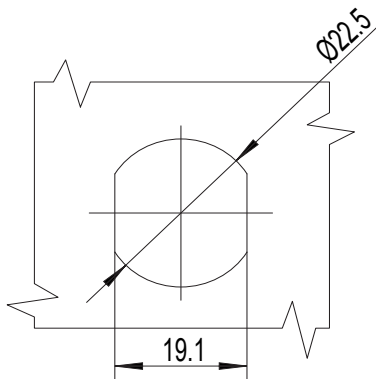

开孔尺寸 (Cut out)

选型 Model selection

C8-1575-036-LH-40L

30 代表电镀亮铬
30 represents electroplating bright chrome
40 代表喷塑亚光黑
40 represents Black powder coated
A1 代表 SUS304
A1 represents SUS304

L 代表钢柱长度
L represents the length of the steel bolt
H 代表有效高度
H represents effective height

旋转 Rotate

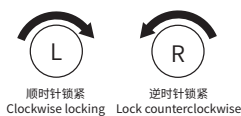

1. Material and surface treatment:
Main body : Zamak DIN-EN 1774-ZnAl4Cu1
Knob: PA66+30%
Locking plate: iron galvanized
Sealing ring: EPDM foam.

2. Performance parameters:
Protection class: IP65
Unlocking torque: $\leq 0.79N/M$
Ultimate load: 700N
Tensioning and stretching amount: 7mm

3. Installation instructions:
Fixed screw torque 10N. M
Fixed nut torque 17N. M
Applicable door panel thickness: 1-15mm

1.材质及表面处理:
主体: 5#锌合金
旋钮: PA66+30%
锁片: 铁镀锌
密封圈: EPDM发泡胶。

2.性能参数:
防护等级: IP65
解锁扭矩: 小于等于 0.79N/M
极限载荷: 700N
拉紧伸缩量: 7mm

3.安装说明:
固定螺丝扭矩 10N.M
固定螺母扭矩 17N.M
适用门板厚度: 1-15mm

如需获得产品 3D 模型图，请联系 WWW.FORND.COM