

A-1212 Rod Control Swinghandle

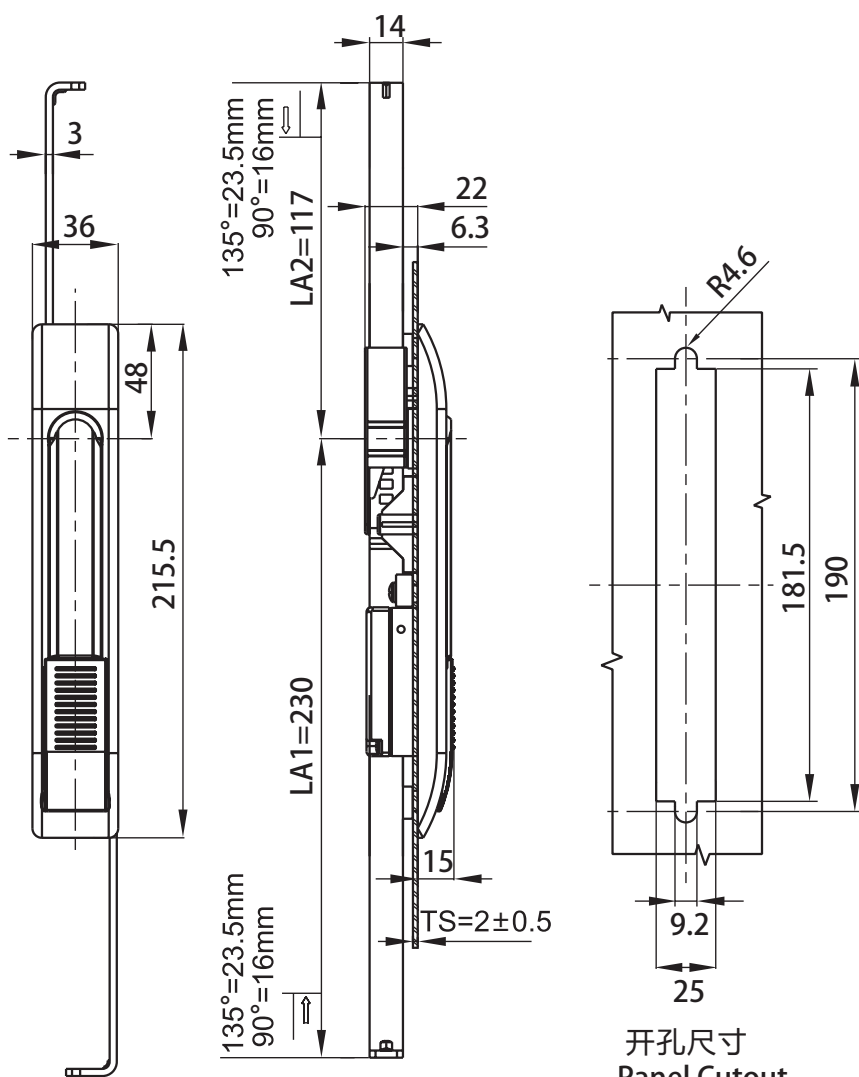

RL

3

IP65



开孔尺寸
Panel Cutout

1. Material and surface treatment:
Lock body: PA66+30%GF;
handle: Zamak DIN-EN 1774-ZnAl40Cu1
Steel bolt: iron galvanized
Sealing ring: EPDM foam.
2. Performance parameters:
Protection class: IP65
Handle bearing tension value: ≤ 490N
Handle bearing torque value: ≤ 26N. m
3. Remark:
Key different on request
CH751 key code on request

1.材质及表面处理:
锁体: PA66+30%GF
手柄: 5#锌合金喷塑黑
螺栓: 铁镀锌
密封圈: EPDM发泡胶。

2.性能参数:
防护等级: IP65
手柄承载力值: ≤ 490N
手柄承载扭矩值: ≤ 26N.m

3.备注: Remark
专用钥匙可选
CH751 钥匙可选

| | |
|----------------------------------|----------------------------------|
| Version A(锁舌型 Cam control) | Version C(三点拉杆型 3Prod control) |
| 麻面黑 Black textured powder coated | 麻面黑 Black Textured powder coated |
| A-1212-1001-60 | A-1212-3001-60 |

如需获得产品 3D 模型图，请联系 WWW.FORND.COM