

Marine compression latch

**A-1530**

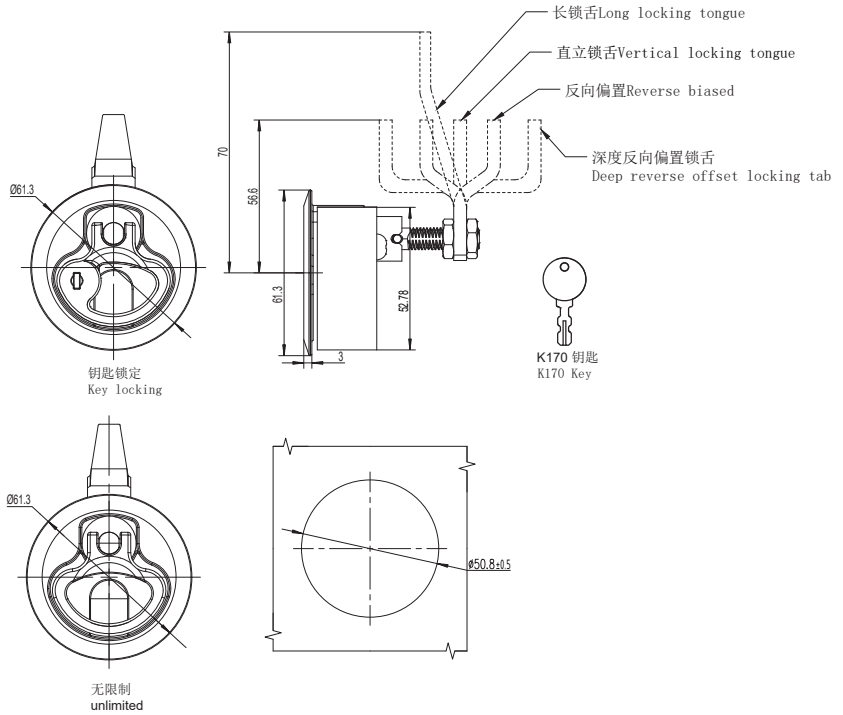

	门板厚度 Door thickness	间距调节值 Gap adjustment value
1	2-12	19
2	12-22.5	9
3	18.5-29	2.5

附注 annotations:

间距范围在 35 及以下的，它们是门板厚度的相关函数，但锁的最小间距值并不一定是取间距范围的最小值，而是取决于实际的门板厚度。在这个间距范围内，可实现的最小间距限制为实际门板厚度 + 间距调节值，或表格内的最小值；两者中取最大值。

The spacing range of 35 and below is a correlation function of the door panel thickness, but the minimum spacing value of the lock does not necessarily take the minimum value of the spacing range, but depends on the actual door panel thickness. Within this spacing range, the minimum achievable spacing limit is the actual door panel thickness+spacing adjustment value, or the minimum value in the table; Take the maximum value between the two.

间距 Grip Range		E	SUS316	
最小 MIN	最大 MAX		K170 钥匙锁定 K170 key locking	不带钥匙锁 Non-locking
21	28	深度偏置前屈 Deep bias forward bend	A-1530-1010-A2	A-1530-2010-A2
27	40	偏置前屈 Bias forward bend	A-1530-1020-A2	A-1530-2020-A2
39	52	直立 upright	A-1530-1030-A2	A-1530-2030-A2
51	64	反向偏置 Reverse bias	A-1530-1040-A2	A-1530-2040-A2
63	76	深度反向偏置 Deep reverse bias	A-1530-1050-A2	A-1530-2050-A2

如需获得产品 3D 模型图，请联系 WWW.FORND.COM

1. Material and surface treatment:  
Lock body, handle: SUS316  
Steel bolt: SUS316  
Sealing ring: EPDM foam

2. Performance parameters:  
Protection class: IP66  
Handle bearing tension value: ≤ 420N  
Maximum static load: 400N

3. Remark:  
Default K170 key code

1. 材质及表面处理:  
锁体, 手柄: SUS316  
钢栓: SUS316  
密封圈: EPDM发泡胶

2. 性能参数:  
防护等级: IP66  
短锁舌最大静载荷: 460N  
长锁舌最大静载荷: 350N

3. 备注:  
默认 K170 钥匙