

# 撞击锁 Push to close latch

**B-1505**

**Paddle lock**

IP40

316L SERIES

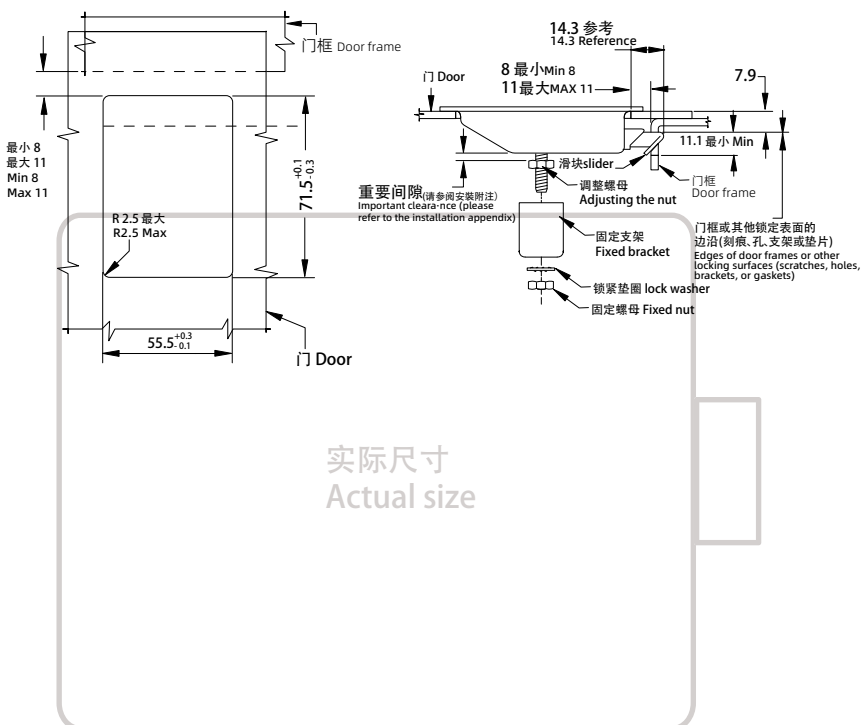
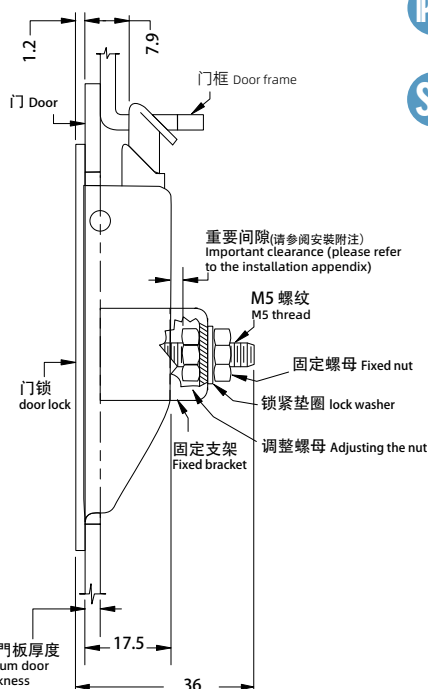
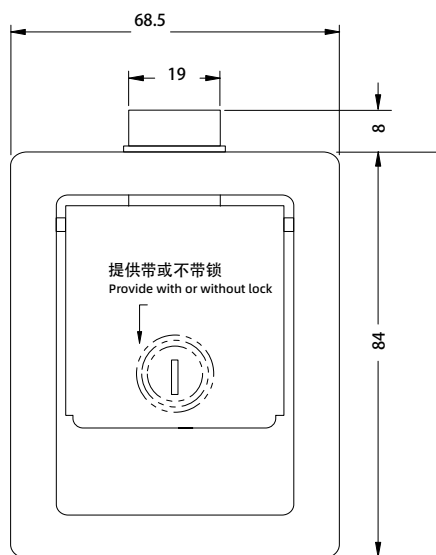

1. Material and surface treatment:  
Lock body, handle : SUS304

2. Performance parameters:  
Protection class: IP40  
Maximum static load: 570N

3. Installation instructions  
Measure the thickness of the door and adjust the nuts to ensure that the spacing is equal to the thickness of the door panel, between +0.8 and -0.0.

4. Remarks:  
Default CH751 key

1. 材质及表面处理:  
锁体, 手柄 : SUS304

2. 性能参数:  
防护等级: IP40  
最大工作载荷: 570N

3. 安装说明  
测量门厚并调整螺母, 确保间距与门板厚度相等, 在 +0.8与 -0.0之间。

4. 备注:  
默认 CH751 钥匙

	SUS304	
	磨砂 sandblast	喷塑黑 Powder coating black
CH751 钥匙锁定 CH751 key locking	B-1505-10-36	B-1505-10-40
无钥匙锁芯 Non-locking	B-1505-11-36	B-1505-11-40