

**A-1205** Rod Control Swinghandle

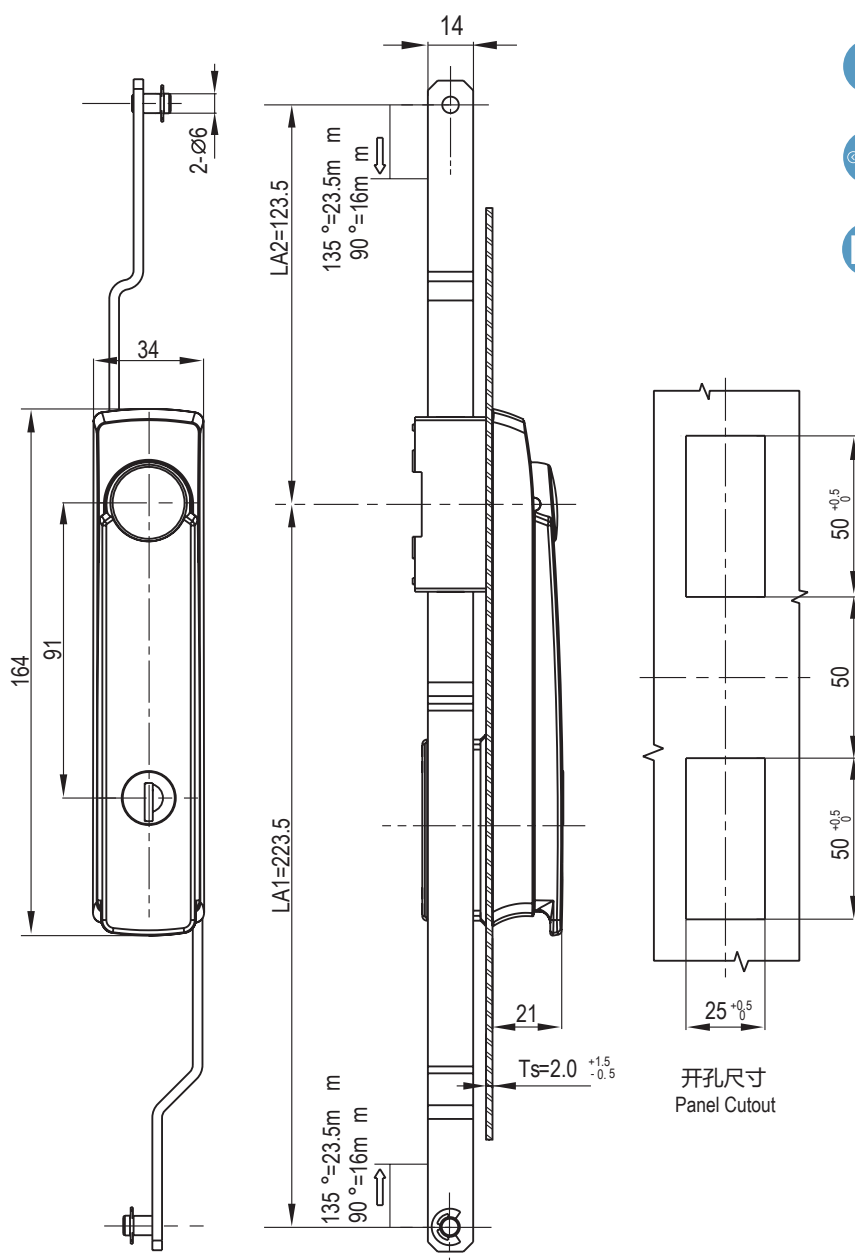

RL

🔒

🔧

IP65



1. Material and surface treatment:  
Lock body: PA66+30%GF;  
handle: Zamak DIN-EN 1774-ZnAl40Cu1  
Steel bolt: iron galvanized  
Sealing ring: EPDM foam.

2. Performance parameters:  
Protection class: IP65  
Handle bearing tension value: ≤ 235N  
Handle bearing torque value: ≤ 40N.m  
Maximum static load: 270N

3. Remarks:  
Optional dedicated key  
CH751 key optional  
Default K333 key

1.材质及表面处理:  
锁体: PA66+30%GF  
手柄: 5#锌合金喷塑黑  
钢栓: 铁镀锌  
密封圈: EPDM发泡胶。

2.性能参数:  
防护等级: IP65  
手柄承载拉力值: ≤ 235N  
手柄承载扭矩值: ≤ 40N.m  
最大静载荷: 270N

3.备注:  
专用钥匙可选  
CH751 钥匙可选  
默认K333钥匙

锁芯 Cylinder style	Version B( 两点拉杆型 2Prod control)	Version C( 三点拉杆型 3Prod control)
半圆柱 K333 相同钥匙 Alike K333 ProPle Round Cylinder	A-1205-2001-64	A-1205-3001-64

如需获得产品 3D 模型图，请联系 WWW.FORND.COM