

A-1113

Swing handle lock

RL

IP65

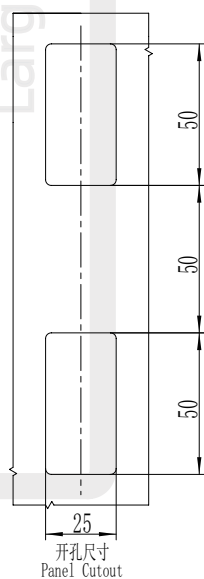
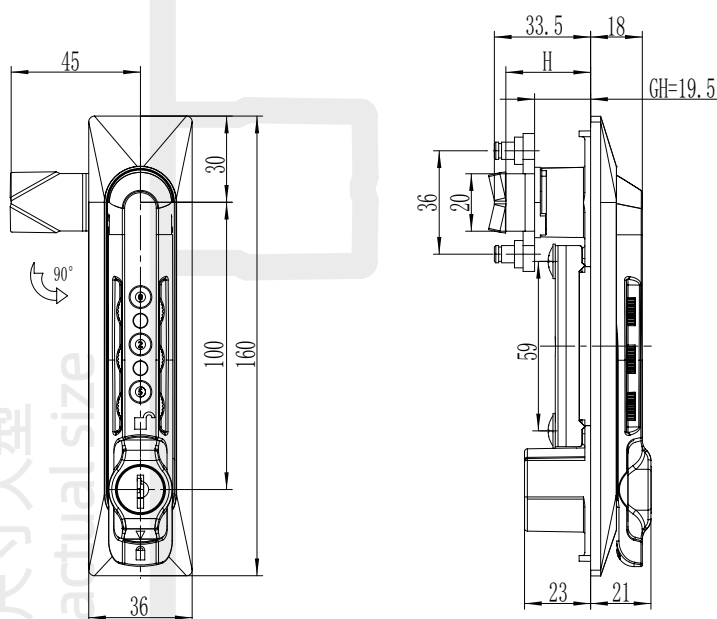

实际尺寸大型

Large actual size

1. Material and surface treatment:
Lock body, handle: PA66+30%GF
Steel bolt: iron galvanized or SUS304
Sealing ring: EPDM foam.

2. Performance parameters:
Protection class: IP65
Handle bearing tension value: $\leq 60\text{N}$
Handle bearing torque value: $\leq 5\text{N}\cdot\text{m}$
Maximum static load: 300N

3. Function Description:
Set the activation password, which can be used to unlock the lock. The administrator can use the management key to unlock or retrieve the password.
Handle opens upwards, 90 degree rotation opens.

4. Remarks:
Default key K333

1. 材质及表面处理:
锁体, 手柄: PA66+30%GF
钢栓: 铁镀锌或 SUS304
密封圈: EPDM发泡胶。

2. 性能参数:
防护等级: IP65
手柄承载拉力值: $\leq 60\text{N}$
手柄承载扭矩值: $\leq 5\text{N}\cdot\text{m}$
最大静载荷: 300N

3. 结构说明: 设置开启密码, 输入密码既可以开锁。管理员使用管理钥匙开启, 或者重新找回密码。手柄向上打开, 90度旋转开启

4. 备注:
默认钥匙 K333

如需获得产品 3D 模型图, 请联系 WWW.FORND.COM

尺寸 Size	全尼龙 PA
大号密码型 Large password combination	A-1111-40-60