

Swing handle lock

**A-1200**

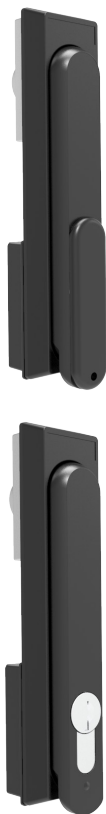

RL



IP65

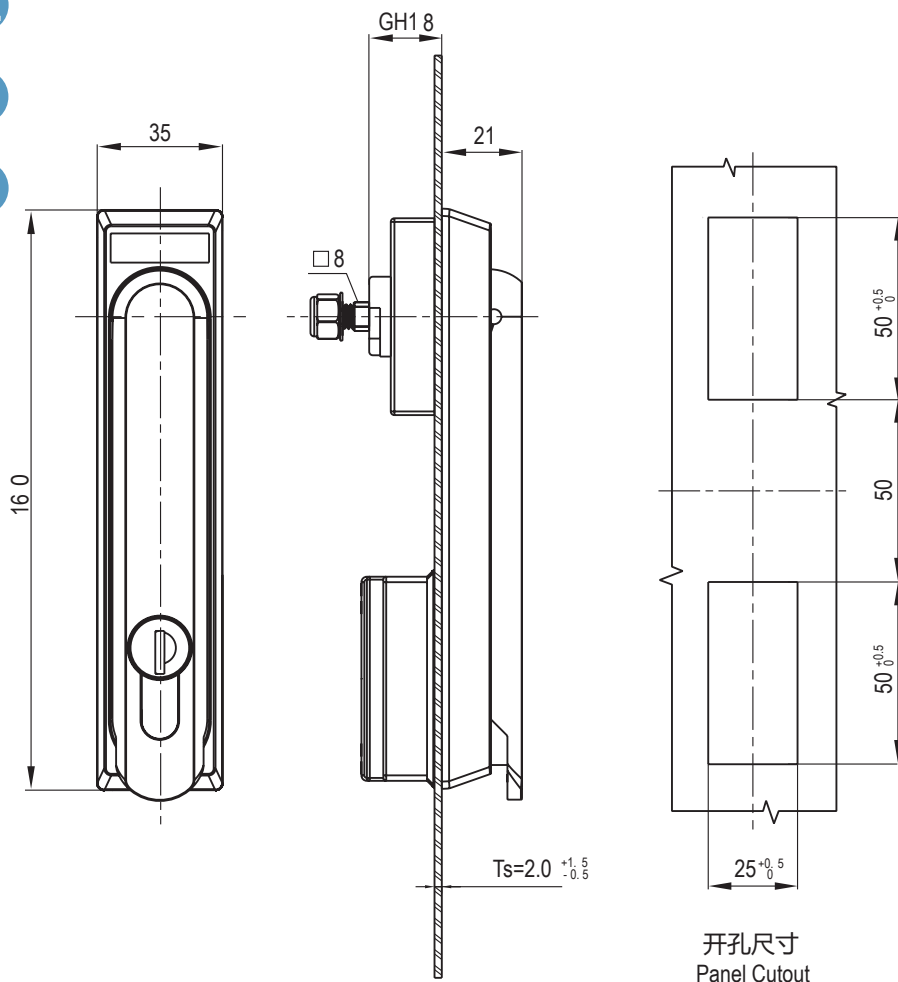

开孔尺寸  
Panel Cutout

如需获得产品3D模型图，请联系 WWW.FORND.COM

1. Material and surface treatment:  
Lock body, handle, dust cover : Zamak  
DIN-EN 1774-ZnAl4Cu1  
Steel bolt: iron galvanized  
Sealing ring: EPDM foam.

2. Performance parameters:  
Protection class: IP65  
Handle bearing tension value:  $\leq 400N$   
Handle bearing torque value:  $\leq 35N \cdot m$

4. Remarks:  
Optional dedicated key  
CH751 key optional  
Can be equipped with stainless steel padlock  
Default K333 key

1. 材质及表面处理:  
锁体, 手柄, 防尘盖: 5# 锌合金喷塑黑  
钢栓: 铁镀锌  
密封圈: EPDM 发泡胶。

2. 性能参数:  
防护等级: IP65  
手柄承载拉力值:  $\leq 400N$   
手柄承载扭矩值:  $\leq 35N \cdot m$

4. 备注:  
专用钥匙可选  
CH751 钥匙可选  
可配不锈钢挂锁  
默认 K333 钥匙

锁芯 Cylinder style	VersionA( 锁舌型 Cam control)	
	有防尘盖 With Dust Cap	无防尘盖 Without Dust Cap
半圆柱 相同钥匙 K333 Alike K333 Proble Round Cylinder	A-1200-1P01-C-40	A-1200-1P01-NC-40
双翅 4mm (Double Bit 4mm)	A-1200-1P02-C-40	A-1200-1P02-NC-40
四方锁芯 7mm (Square 7mm)	A-1200-1P03-C-40	A-1200-1P03-NC-40
三角锁芯 8mm (Triangular 8mm)	A-1200-1P04-C-40	A-1200-1P04-NC-40