

A-1203 Rod Control Swinghandle

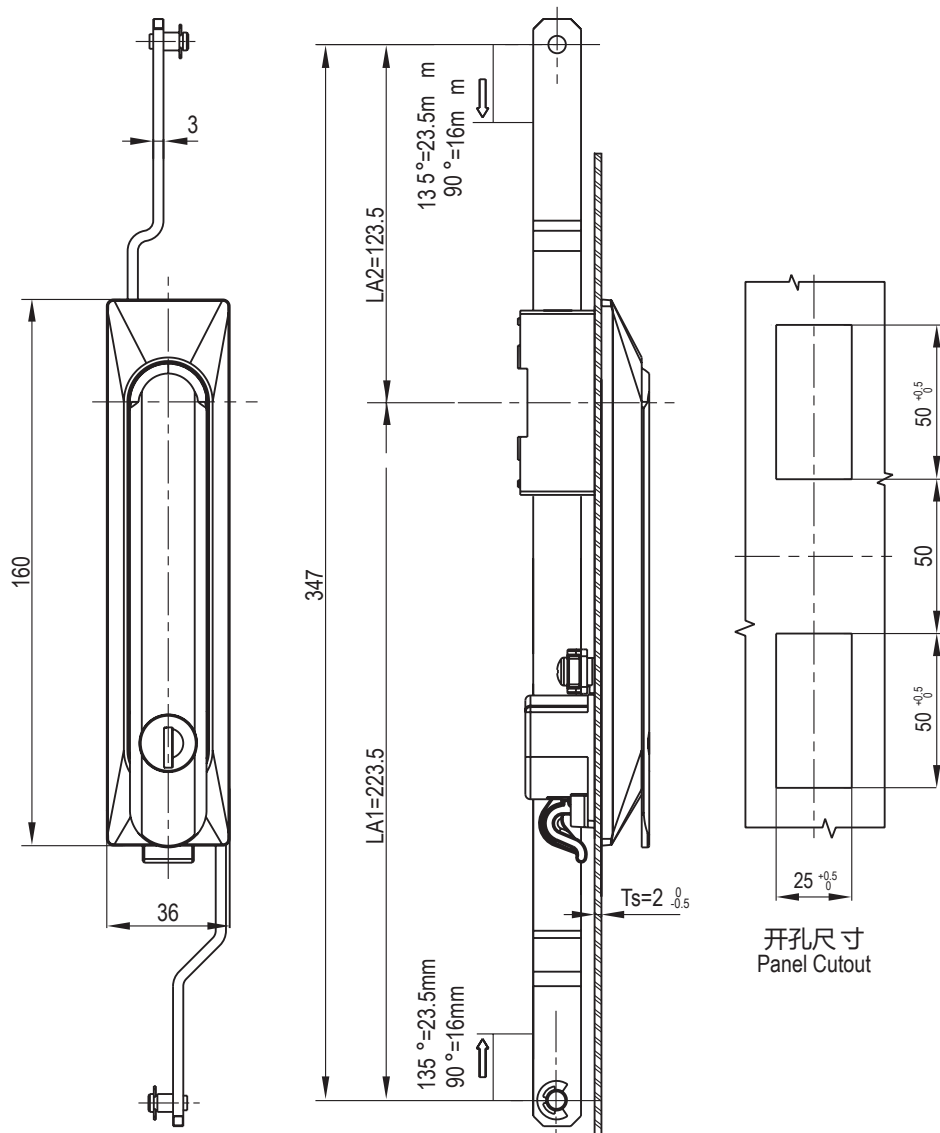

RL

🔒

🔒

IP65



开孔尺寸
Panel Cutout

1. Material and surface treatment:
Lock body: PA66+30%GF;
handle: Zamak DIN-EN 1774-ZnAl40Cu1
Steel bolt: iron galvanized
Sealing ring: EPDM foam.

2. Performance parameters:
Protection class: IP65
Handle bearing tension value: ≤ 300N
Handle bearing torque value: ≤ 33N.m

3. Remarks:
Optional dedicated key
CH751 key optional
Can be equipped with stainless steel padlock
Default K333 key

1. 材质及表面处理:
锁体: PA66+30%GF
手柄: 5#锌合金喷塑黑
钢栓: 铁镀锌
密封圈: EPDM发泡胶。

2. 性能参数:
防护等级: IP65
手柄承载拉力值: ≤ 300N
手柄承载扭矩值: ≤ 33N.m

3. 备注:
专用钥匙可选
CH751 钥匙可选
可配不锈钢挂锁
默认 K333 钥匙

Version B (2点拉杆型 2Prod cotrol)	Version C (三点拉杆型 3Prod control)
A-1203-2001-60	A-1203-3001-64