

A-1204 Rod Control Swinghandle

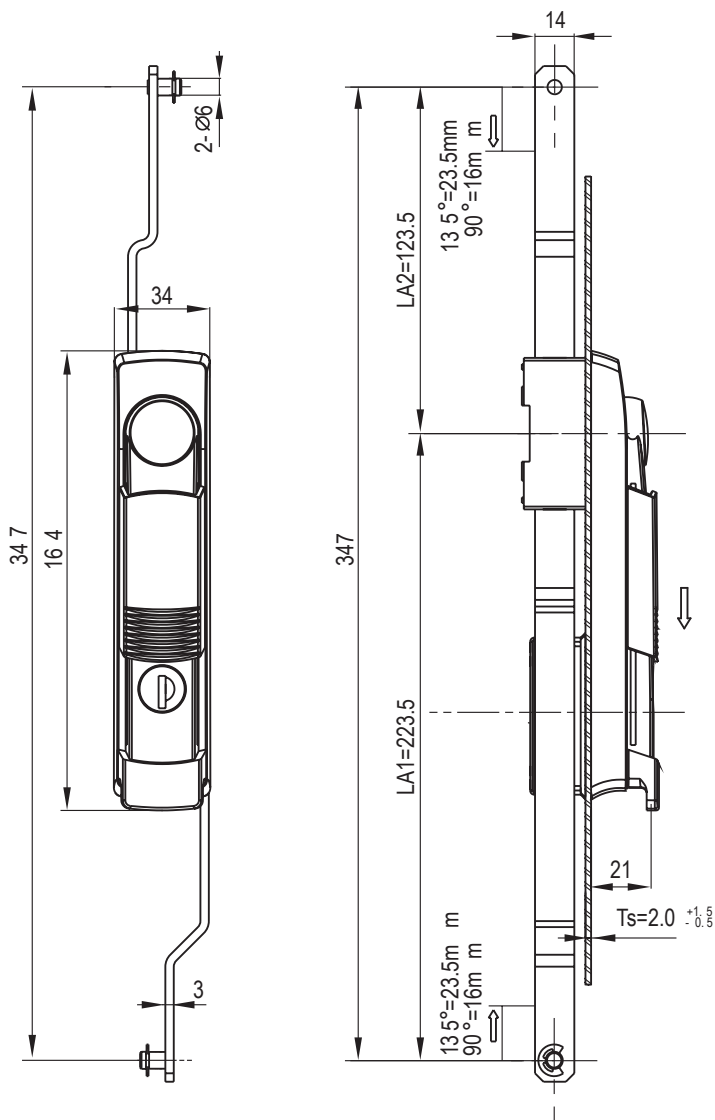

RL

3

IP65



1. Material and surface treatment:
Lock body, handle: PA66+30%GF
Steel bolt: iron galvanized
Sealing ring: EPDM foam.

2. Performance parameters:
Protection class: IP65
Handle bearing tension value: $\leq 520\text{N}$
Handle bearing torque value: $\leq 27\text{N}\cdot\text{m}$
Maximum static load: 270N

3. Remarks:
Optional dedicated key
CH751 key optional
Default K333 key

1. 材质及表面处理:
锁体, 手柄: PA66+30%GF
钢栓: 铁镀锌
密封圈: EPDM发泡胶。

2. 性能参数:
防护等级: IP65
手柄承载拉力值: $\leq 520\text{N}$
手柄承载扭矩值: $\leq 27\text{N}\cdot\text{m}$
最大静载荷: 270N

3. 备注:
专用钥匙可选
CH751 钥匙可选
默认K333钥匙

锁芯 Cylinder style	Version B(两点拉杆型 2Prod control)	Version C(三点拉杆型 3Prod control)
	有防尘盖 With Dust Cap	无防尘盖 Without Dust Cap
圆柱 K333 相同钥匙 Alike K333 Round Cylinder	A-1204-2001-60	A-1204-3001-60

如需获得产品 3D 模型图，请联系 WWW.FORND.COM