

Swing handle lock

**A-1205**

RL



IP65

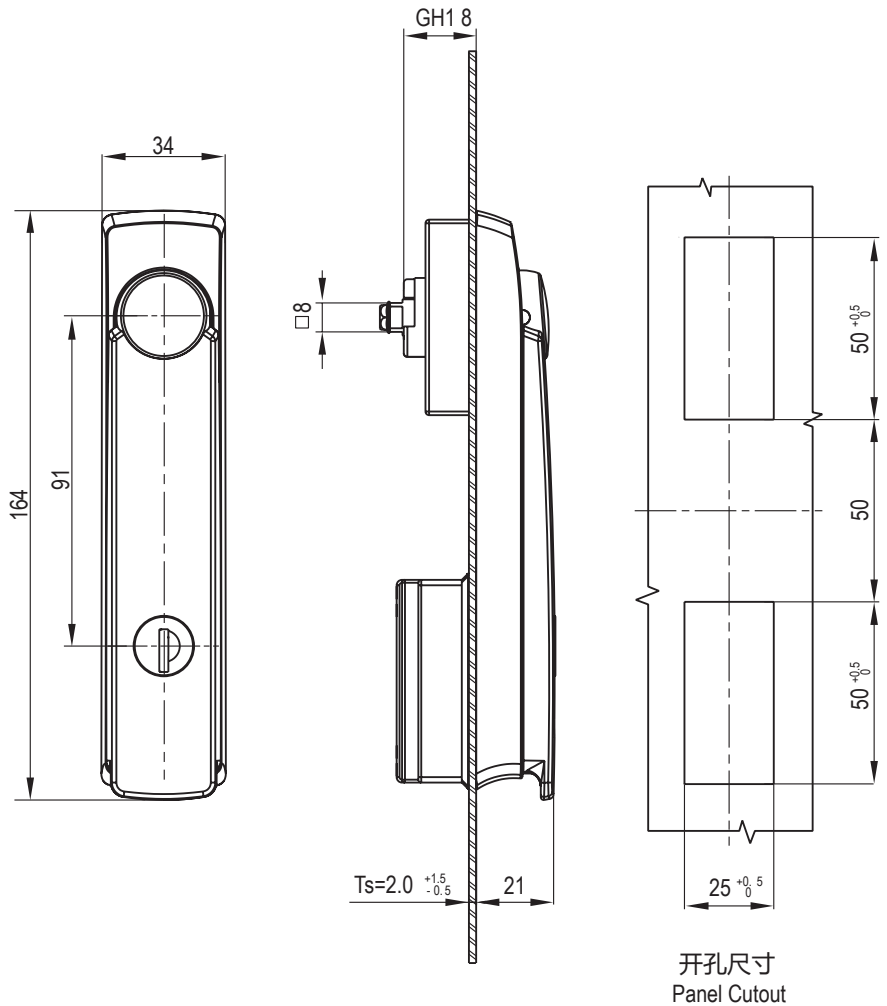

开孔尺寸  
Panel Cutout

如需获得产品3D模型图，请联系WWW.FORND.COM

1. Material and surface treatment:  
Lock body: PA66+30%GF;  
handle: Zamak DIN-EN 1774-ZnAl40Cu1  
Steel bolt: iron galvanized  
Sealing ring: EPDM foam.

2. Performance parameters:  
Protection class: IP65  
Handle bearing tension value:  $\leq 235N$   
Handle bearing torque value:  $\leq 40N \cdot m$   
Maximum static load: 270N

3. Remarks:  
Optional dedicated key  
CH751 key optional  
Default K333 key

1. 材质及表面处理:  
锁体: PA66+30%GF  
手柄: 5#锌合金喷塑黑  
钢栓: 铁镀锌  
密封圈: EPDM发泡胶。

2. 性能参数:  
防护等级: IP65  
手柄承载拉力值:  $\leq 235N$   
手柄承载扭矩值:  $\leq 40N \cdot m$   
最大静载荷: 270N

3. 备注:  
专用钥匙可选  
CH751 钥匙可选,  
默认K333钥匙

锁芯 Cylinder style	VersionA(锁舌型 Cam control)
半圆柱 333 相同钥匙 Alike K333 Profile Round Cylinder	A-1205-1001-64