

Swing handle lock

A-1113

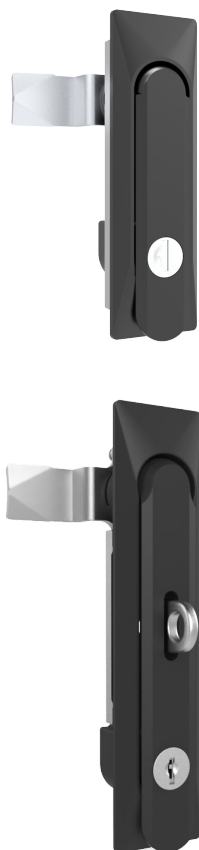

RL

IP65

IP65

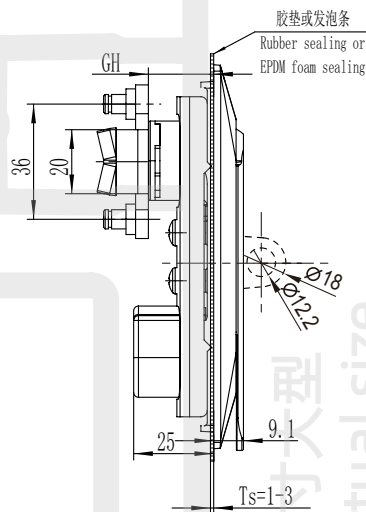
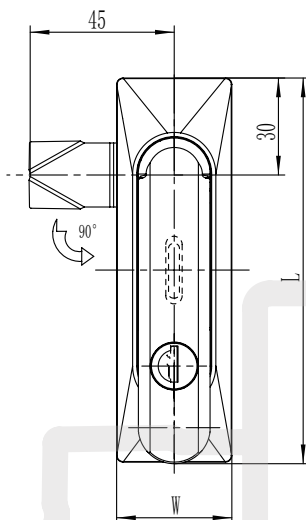

实际尺寸小型
Small actual size

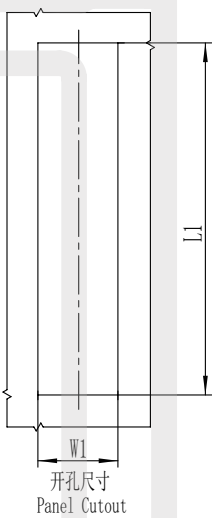

实际尺寸中型
Medium actual size

实际尺寸大型
Large actual size

如需获得产品3D模型图，请联系 WWW.FORND.COM

1. Material and surface treatment:
Lock body, handle: Zamak DIN-EN 1774-ZnAl4Cu1 or PA66+30%GF
Steel bolt: iron galvanized or SUS304
Sealing ring: EPDM foam.
2. Performance parameters:
Protection class: IP65
Handle bearing tension value: $\leq 390\text{N}$
Handle bearing torque value: $\leq 12\text{N}\cdot\text{m}$
Maximum static load: 300N
3. Function Description:
Open the handle upwards and rotate it 90° to achieve opening
4. Remarks:
Default key K333

1. 材质及表面处理:
锁体, 手柄: 5#锌合金或 PA66+30%GF
钢栓: 铁镀锌或 SUS304
密封圈: EPDM发泡胶。
2. 性能参数:
防护等级: IP65
手柄承载拉力值: $\leq 390\text{N}$
手柄承载扭矩值: $\leq 12\text{N}\cdot\text{m}$
最大静载荷: 300N
3. 功能描述:
手柄向上打开, 90°旋转实现开启
4. 备注:
默认钥匙 K333

尺寸 Size	L	W	L1	W1	GH
小型 Small	80mm	36mm	70mm	25mm	20mm
中型 Medium	120mm	36mm	110mm	25mm	20mm
大型 Large	160mm	36mm	120mm	25mm	18mm

尺寸 Size	全锌合金 Zinc alloy		全尼龙 PA		锌合金手柄, 塑料座 Zinc die handle, PA housing	
	不带挂 Without padlock	带挂 Padlockable	不带挂 Without padlock	带挂 Padlockable	不带挂 Without padlock	带挂 Padlockable
小号 Small	A-1113-10-40		A-1111-10-60		A-1111-10-64	
中号 Medium	A-1111-20-40	A-1111-22-40	A-1111-20-60	A-1111-22-60	A-1111-20-64	A-1111-22-64
大号 Large	A-1113-30-40	A-1113-32-40	A-1111-30-60	A-1111-32-60	A-1111-30-64	A-1111-32-64