

H2-2308

External Hinge

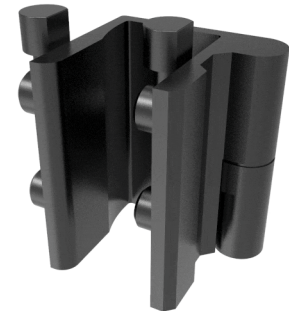

A+E

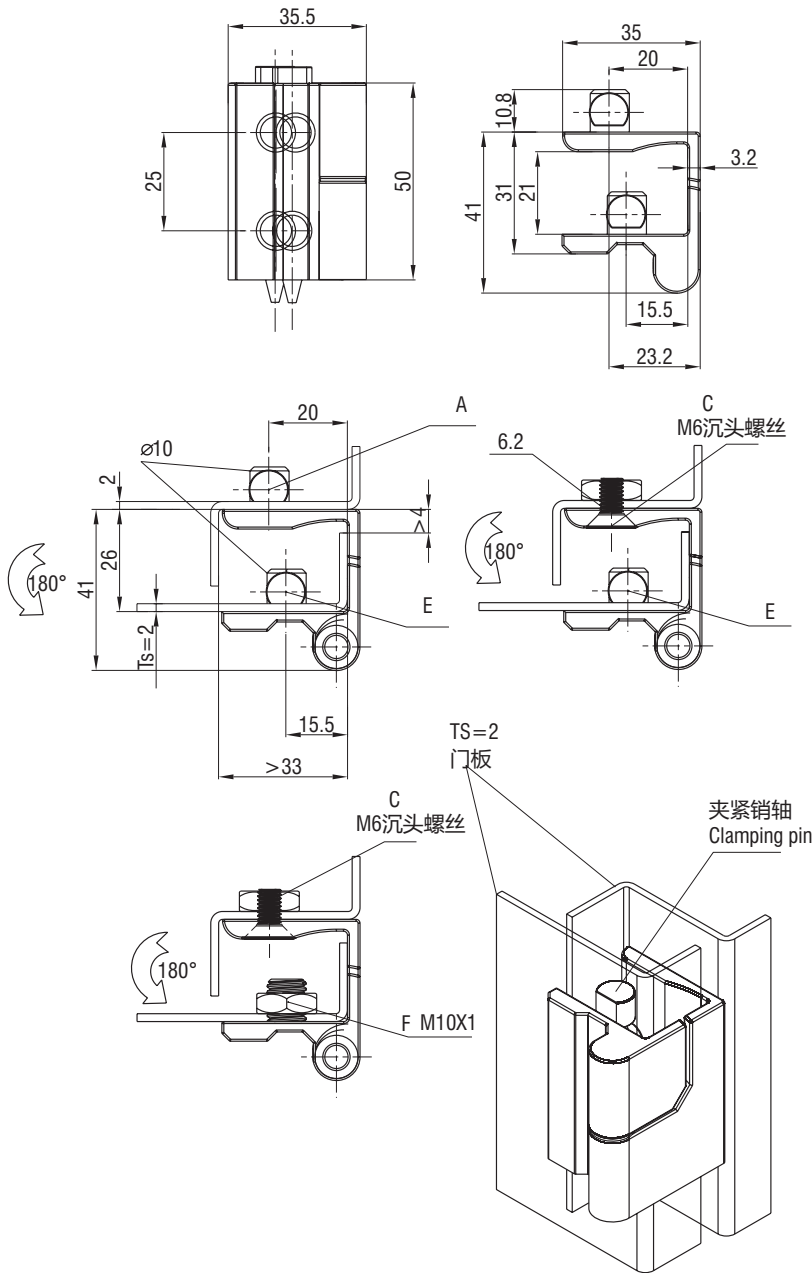

C+E



C+F

型式 Type	全锌合金 Zinc die		铁框件, 锌合金门板 Steel frame leaf, zinc die door leaf		全不锈钢 SUS 316	
	左装 Version (Left)	右装 Version (Right)	左装 Version (Left)	右装 Version (Right)	左装 Version (Left)	右装 Version (Right)
A+E	H2-2308-111AE-42	H2-2308-111AE-42				
C+E	H2-2308-111CE-42	H2-2308-111CE-42	H2-2308-111CE-142	H2-2308-111CE-142		
C+F	H2-2308-111CF-42	H2-2308-111CF-42	H2-2308-111CF-142	H2-2308-111CF-142	H2-2308-111CF-A2	H2-2308-111CF-A2

1. Material and surface treatment:
Main body : Zamak DIN-EN 1774-ZnAl4Cu1 or SUS316

1. 材质及表面处理:
主体: 5#锌合金 或 SUS316