

## H1-2315

### Screw-on Hinge

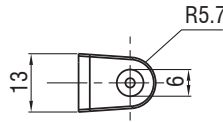
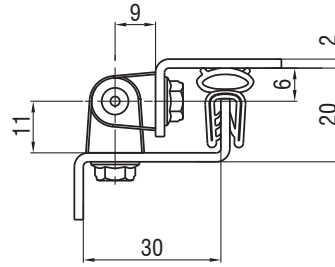
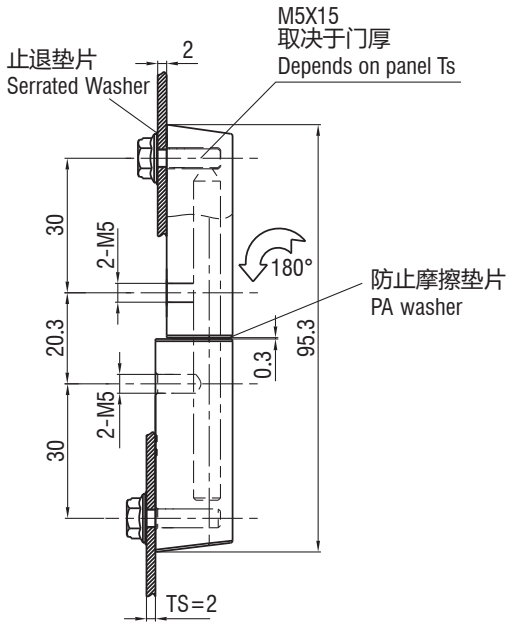

1. Material and surface treatment:  
Main body : Zamak DIN-EN 1774-ZnAl4Cu1

1. 材质及表面处理:  
主体: 5# 锌合金

## H1-2317

### Screw-on Hinge

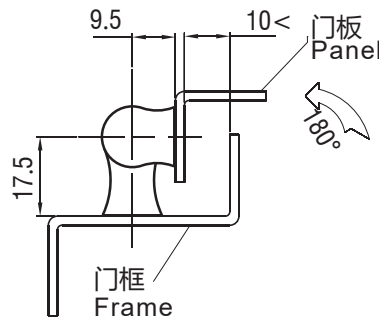
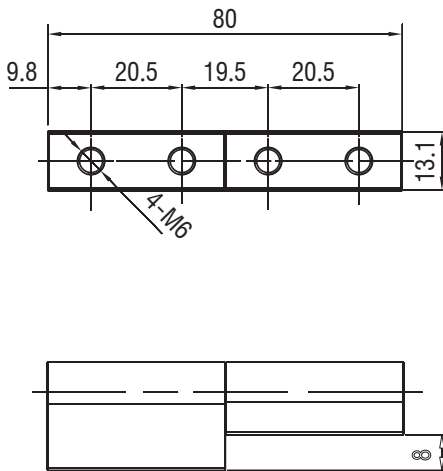

1. Material and surface treatment:  
Main body : M.S. zinc plated or SUS304

1. 材质及表面处理:  
主体: 镀锌钢 或 SUS304

如需获得产品 3D 模型图，请联系 WWW.FORND.COM

亮铬 Bright Chrome	亮铬 Bright Chrome
H1-2317-30	H1-2317-A1