

H1-2308

Screw-on Hinge

接合套Receiver

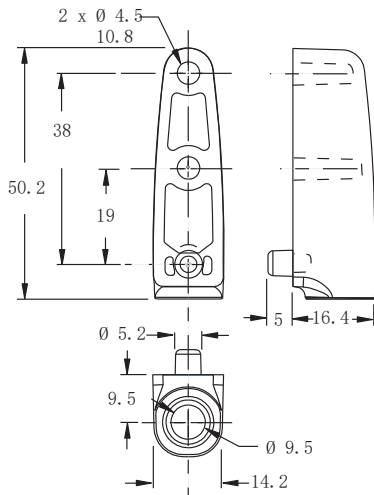

销钉Pin

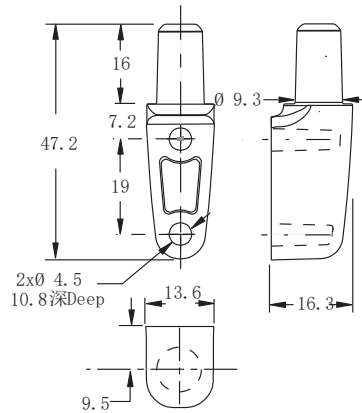

偏置固定
Offset Mount

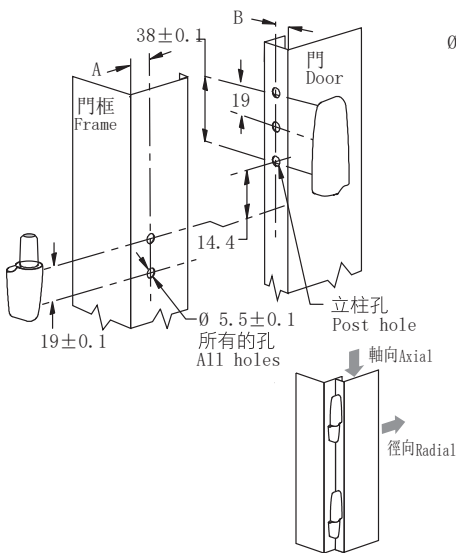

齐平固定
Flush Mount

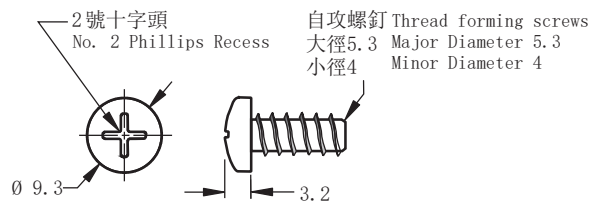
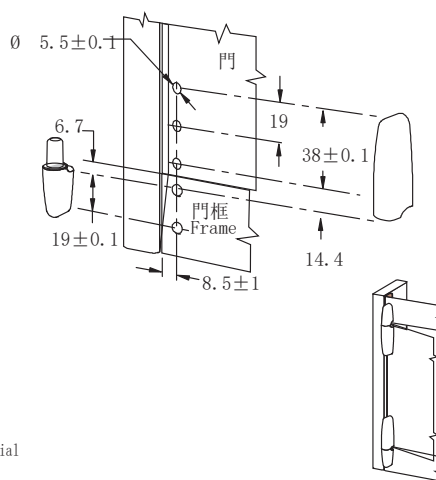

Installation Notes:
Recommended tightening torque
for mounting screws:
1.6 N/m

Offset mount preparation:
To allow for 180° rotation A or B must be
8.5±1

安装说明:
推荐的固定螺钉拧紧力矩:
1.6N/m
偏置固定准备:
要允许180度旋转, A或B必须为8.5±1

黑色 Black	径向载荷 Radial Load	轴向载荷 Axial Load
最大静载荷 Max static load	700N	1200N
平均极限载荷 Average ultimate load	1000N	3500N

镀铬 Chrome	径向载荷 Radial Load	轴向载荷 Axial Load
最大静载荷 Max static load	350N	900N
平均极限载荷 Average ultimate load	600N	2200N

1. Material and surface treatment:
Main body : Black: Glass-Pled nylon
Chrome: PC/ABS blend, chrome

1. 材质及表面处理:
主体: 黑色: 尼龙加玻纤
镀铬: PC/ABS混合, 镀铬

黑色 Black	镀铬 Chrome
H1-2308-40	H1-2308-30