

Screw-on Hinge

H1-2103

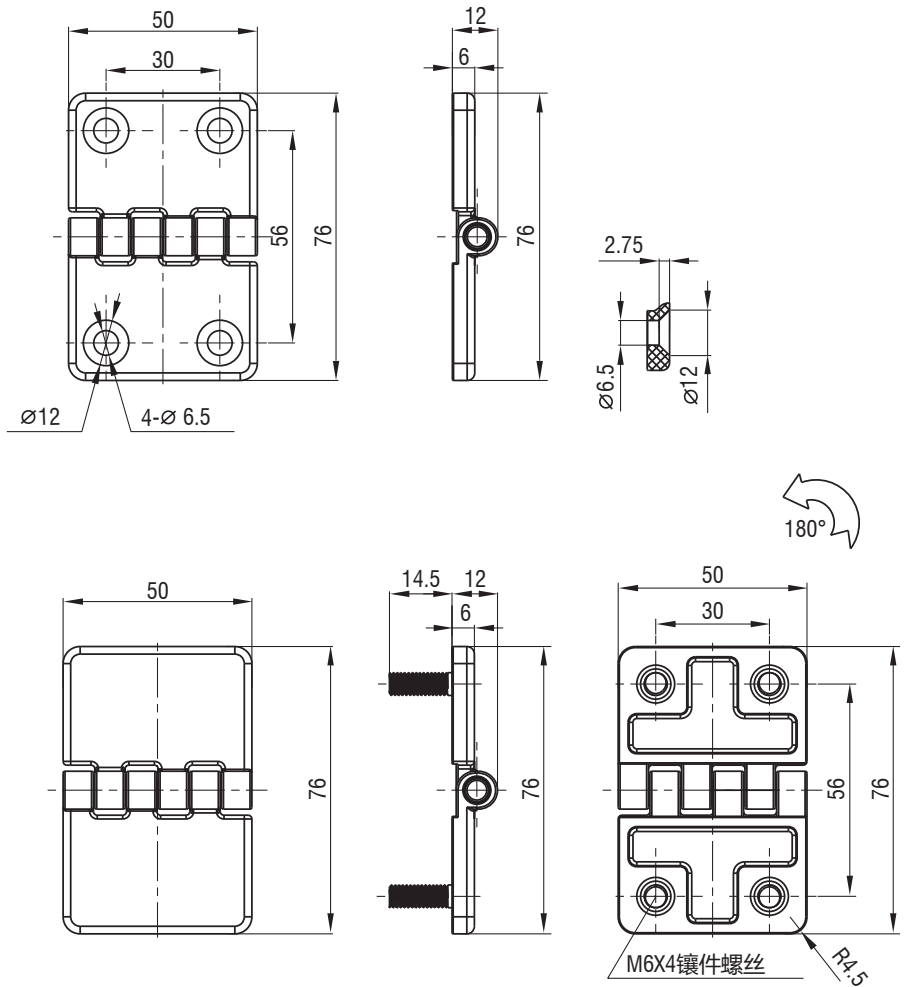

M6 沉头螺钉固定 Countersunk Screw M6



如需获得产品3D模型图，请联系 WWW.FORND.COM

1. Material and surface treatment:
Main body : Zamak DIN-EN 1774-ZnAl4Cu1
or SUS304

1. 材质及表面处理:
主体: 5#锌合金或 SUS304

表面处理 Finish	M6 沉头螺钉固定 Countersunk Screw M6	M6 镶嵌螺柱 With Threaded Studs M6
喷塑黑 Black Powder Coated	H1-2103-760-40	H1-2103-761-40
亮铬 Bright Chrome	H1-2103-760-30	H1-2103-761-30
SUS304	H1-2103-760-A1	H1-2103-761-A1