

D1-1449

quarter turn lock

IP65

STAINLESS SERIES

RL

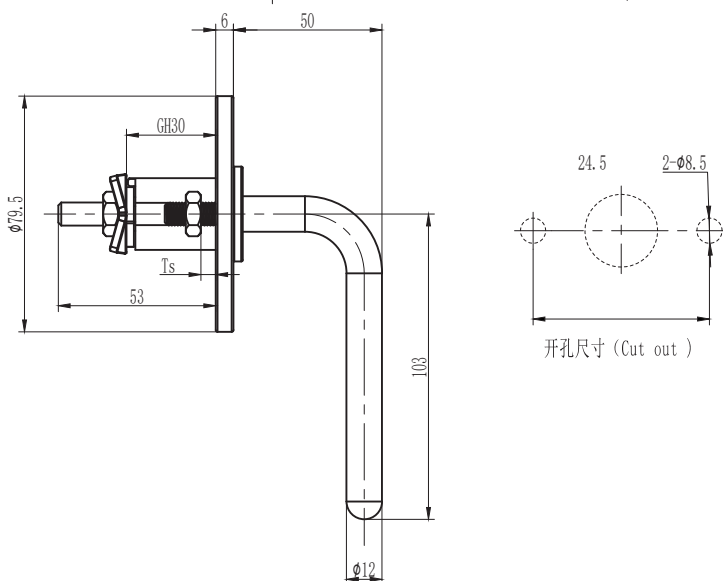
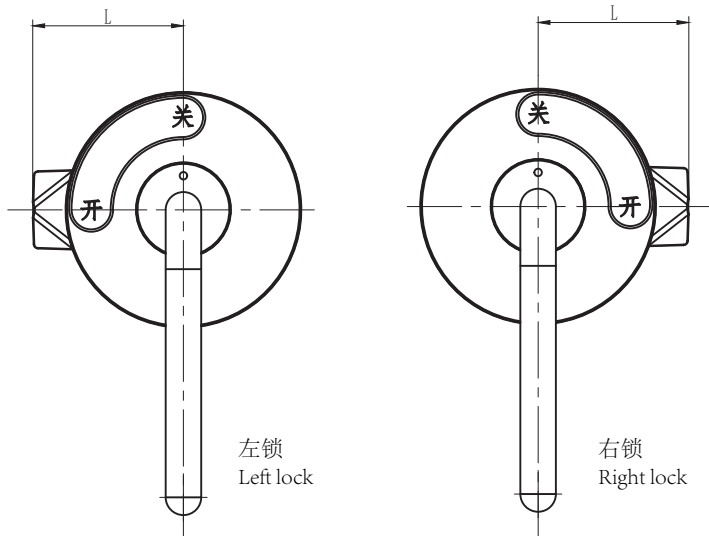

选型 Model selection

D1-1449-LH-A1L

A1 代表 SUS304
A1 represents SUS304
L 代表左锁 顺时针旋转锁紧
L represents clockwise rotation and locking of the left lock
R 代表右锁 逆时针旋转锁紧
R represents the counterclockwise

L 代表钢柱长度
L represents the length of the steel bolt
H 代表有效高度
H represents effective height

1. Material and surface treatment:
Main body: Zamak DIN-EN 1774-ZnAl4Cu1 and SUS304
Handle panel, Steel bolt: SUS304
Sealing ring: EPDM foam.

2. Performance parameters:
Protection class: IP65

3. Installation instructions:
Fixed screw torque 8N. M
Fixed nut torque 17N. M
Applicable door panel thickness: 1-5mm

1. 材质及表面处理:
主体: 5# 锌合金 和 SUS304
手柄面板, 钢柱: SUS304
密封圈: EPDM发泡胶

2. 性能参数:
防护等级: IP65

3. 安装说明:
固定螺丝扭矩 8N.M
固定螺母扭矩 17N.M
适用门板厚度: 1-5mm

如需获得产品 3D 模型图, 请联系 WWW.FORND.COM