

D1-1421

quarter turn lock

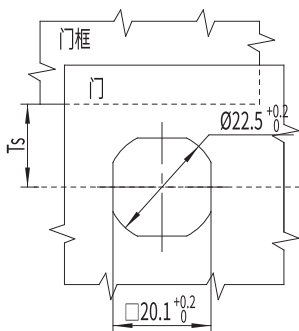
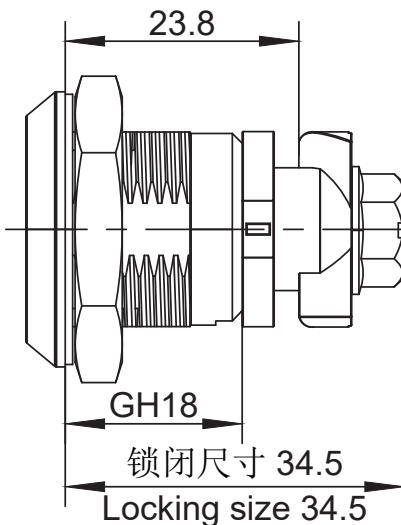
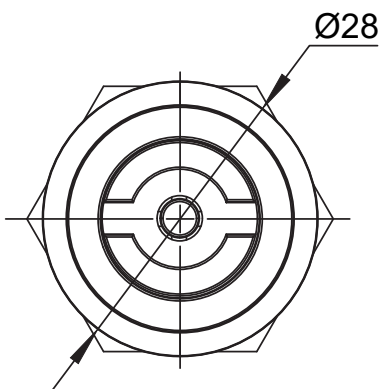

IP65

STAINLESS SERIES



锁芯 Cylinder

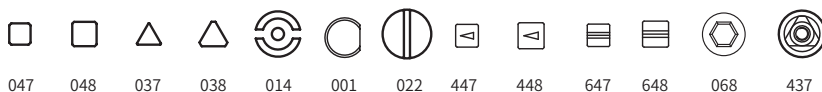

选型 Model selection

锁芯选型
Lock cylinder selection

D1-1421-SX-LH-30

30 代表电镀亮铬
30 represents electroplating bright chrome
40 代表喷塑亚光黑
40 represents Black powder coated
A1 代表 SUS304
A1 represents SUS304

L 代表钢栓长度
L represents the length of the steel bolt
H 代表有效高度
H represents effective height

1. Material and surface treatment:
Main body, Steel bolt : Zamak DIN-EN 1774-ZnAl4Cu1 or SUS304
2. Performance parameters:
Protection class: IP65
3. Installation instructions:
Fixed screw torque 8N. M
Fixed nut torque 17N. M
Applicable door panel thickness: 1-5mm

1. 材质及表面处理:
主体, 钢栓: 5# 锌合金 或 SUS304
密封圈: EPDM 发泡胶

2. 性能参数:
防护等级: IP65

3. 安装说明:
固定螺丝扭矩 8N.M
固定螺母扭矩 17N.M
适用门板厚度: 1-5mm

如需获得产品 3D 模型图, 请联系 WWW.FORND.COM