

**D1-1436**

quarter turn lock

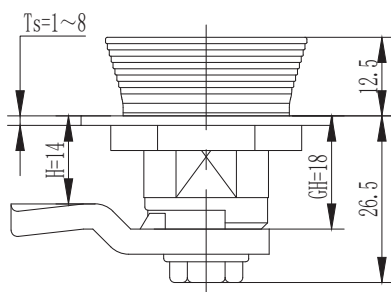
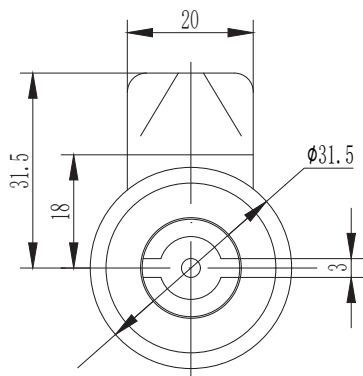

IP65

STAINLESS SERIES

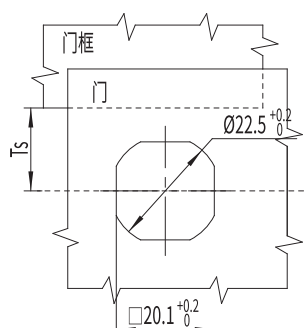

选型 Model selection

**D1-1436-013-LH-42**

42 粉末涂层, 孔雀绿  
42 powder coating, peacock green

L 代表钢栓长度  
L represents the length of the steel bolt  
H 代表有效高度  
H represents effective height

1. Material and surface treatment:  
Main body, Steel bolt : Zamak DIN-EN 1774-ZnAl4Cu1 or SUS304

2. Performance parameters:  
Protection class: IP65

3. Installation instructions:  
Fixed screw torque 8N. M  
Fixed nut torque 17N. M  
Applicable door panel thickness: 1-5mm

1. 材质及表面处理:  
主体, 钢栓: 5# 锌合金 或 SUS304  
密封圈: EPDM发泡胶

2. 性能参数:  
防护等级: IP65

3. 安装说明:  
固定螺丝扭矩 8N.M  
固定螺母扭矩 17N.M  
适用门板厚度: 1-5mm

如需获得产品 3D 模型图, 请联系 WWW.FORND.COM