

C6-1511 compression cam latch

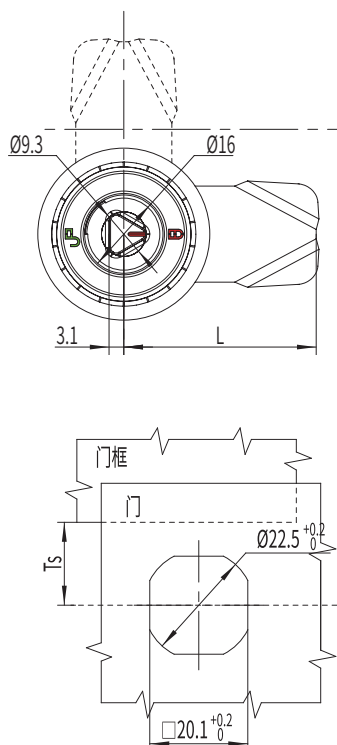

RL

IP65



锁芯 Cylinder

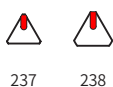

选型 Model selection

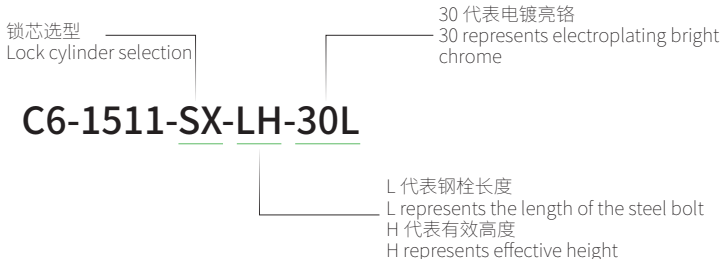

旋转 Rotate



- Material and surface treatment:
Main body : Zamak DIN-EN 1774-ZnAl4Cu1
Steel bolt: iron galvanized
Sealing ring: EPDM foam.
- Performance parameters:
Protection class: IP65
Unlocking torque: $\leq 0.79N/M$
Ultimate load: 700N
Tensioning and stretching amount: 7mm
- Installation instructions:
Fixed screw torque 8N. M
Fixed nut torque 17N. M
Applicable door panel thickness: 1-5mm

- 材质及表面处理:
主体: 5#锌合金
钢柱: 铁镀锌
密封圈: EPDM发泡胶。
- 性能参数:
防护等级: IP65
解锁扭矩: 小于等于 0.79N/M
极限载荷: 700N
拉紧伸缩量: 7mm
- 安装说明:
固定螺丝扭矩 8N.M
固定螺母扭矩 17N.M
适用门板厚度: 1-5mm

如需获得产品 3D 模型图，请联系 WWW.FORND.COM