

quarter turn lock

**D1-1420**



IP65

S  
S  
SERIES

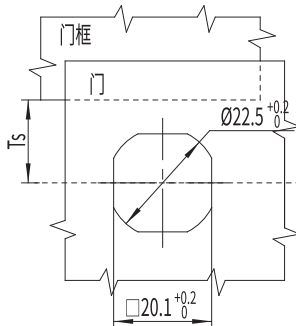
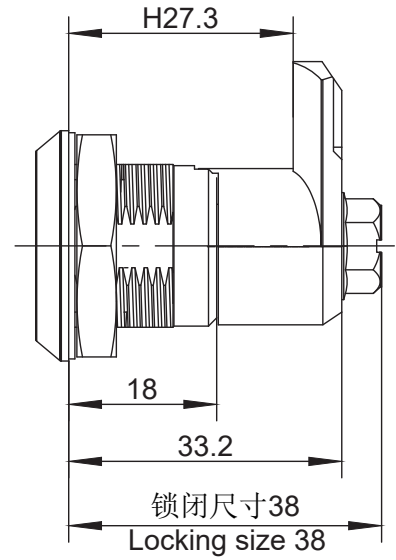
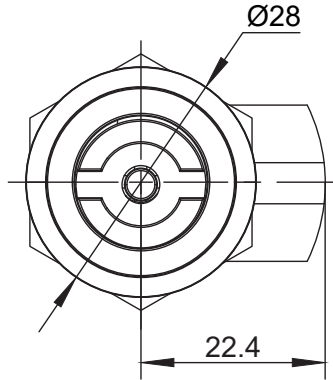

### 锁芯 Cylinder

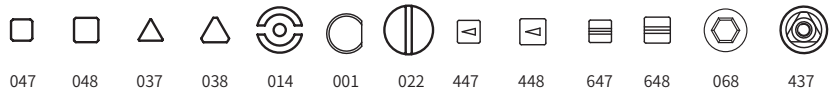

### 选型 Model selection

锁芯选型  
Lock cylinder selection

**D1-1420-SX-LH-30**

30 代表电镀亮铬  
30 represents electroplating bright chrome  
40 代表喷塑亚光黑  
40 represents Black powder coated  
A1 代表 SUS304  
A1 represents SUS304

L 代表钢栓长度  
L represents the length of the steel bolt  
H 代表有效高度  
H represents effective height

如需获得产品3D模型图，请联系 WWW.FORND.COM

1. Material and surface treatment:  
Main body, Steel bolt : Zamak DIN-EN 1774-ZnAl4Cu1 or SUS304

2. Performance parameters:  
Protection class: IP65

3. Installation instructions:  
Fixed screw torque 8N. M  
Fixed nut torque 17N. M  
Applicable door panel thickness: 1-5mm

1. 材质及表面处理:  
主体, 钢栓: 5# 锌合金 或 SUS304  
密封圈: EPDM发泡胶

2. 性能参数:  
防护等级: IP65

3. 安装说明:  
固定螺丝扭矩 8N.M  
固定螺母扭矩 17N.M  
适用门板厚度: 1-5mm